

Instruction Manual

RESIDENTIAL SOLAR

WATER HEATING SYSTEM

FOR POTABLE WATER
HEATING ONLY



Solar Water Heater



Solar Collector
SRCC OG-100



⚠ WARNING

Read and understand this instruction manual and safety messages before installing, operating, or servicing this water heater.

Failure to follow these instructions and safety messages could result in death or serious injury.

This manual must remain with water heater.

ALL TECHNICAL AND WARRANTY QUESTIONS: SHOULD BE DIRECTED TO THE LOCAL DEALER FROM WHOM THE WATER HEATER WAS PURCHASED. IF YOU ARE UNSUCCESSFUL, PLEASE WRITE TO THE COMPANY LISTED ON THE RATING PLATE ON THE WATER HEATER.





**KEEP THIS MANUAL IN THE POCKET ON HEATER FOR FUTURE REFERENCE
WHEN EVER MAINTENANCE ADJUSTMENT OR SERVICE IS REQUIRED.**

SAFE INSTALLATION, USE AND SERVICE

Your safety and the safety of others is extremely important in the installation, use, and servicing of this water heater.

Many safety-related messages and instructions have been provided in this manual and on your own water heater to warn you and others of a potential injury hazard. Read and obey all safety messages and instructions throughout this manual. It is very important that the meaning of each safety message is understood by you and others who install, use, or service this water heater.

	<p>This is the safety alert symbol. It is used to alert you to potential personal injury hazards. Obey all safety messages that follow this symbol to avoid possible injury or death.</p>
---	--

	<p>DANGER indicates an imminently hazardous situation which, if not avoided, will result in death or injury.</p>
	<p>WARNING indicates a potentially hazardous situation which, if not avoided, could result in death or injury.</p>
	<p>CAUTION indicates a potentially hazardous situation which, if not avoided, could result in minor or moderate injury.</p>
	<p>CAUTION used without the safety alert symbol indicates a potentially hazardous situation which, if not avoided, could result in property damage.</p>

All safety messages will generally tell you about the type of hazard, what can happen if you do not follow the safety message, and how to avoid the risk of injury.

The California Safe Drinking Water and Toxic Enforcement Act requires the Governor of California to publish a list of substances known to the State of California to cause cancer, birth defects, or other reproductive harm, and requires businesses to warn of potential exposure to such substances.

WARNING: This product contains a chemical known to the State of California to cause cancer, birth defects, or other reproductive harm.

This appliance can cause low-level exposure to some of the substances listed in the act.

Hydrogen gas can be produced in a hot water system that has not been used for a long period of time (generally two weeks or more). Hydrogen gas is extremely flammable and can ignite when exposed to a spark or flame. To prevent the possibility of injury under these conditions, we recommend the hot water faucet be opened for several minutes at the kitchen sink before using any electrical appliance which is connected to the hot water system. If hydrogen is present, there will probably be an unusual sound such as air escaping through the faucet as water begins to flow. Do not smoke or have any open flame near the faucet at the time it is open.

IMPORTANT DEFINITIONS

- **Qualified Installer:** A qualified installer must have ability equivalent to a licensed tradesman in the fields of plumbing and electrical installation of these appliances. This would include a thorough understanding of the requirements of the National Electrical Code and applicable local electrical and plumbing codes (and tools necessary to confirm proper installation and operation of the water heater) as they relate to the installation of electric water heaters. The qualified installer must have a thorough understanding of the water heater Instruction Manual.
- **Service Agency:** A service agency also must have ability equivalent to a licensed tradesman in the fields of plumbing and electrical installation of these appliances. This would include a thorough understanding of the requirements of the National Electrical Code and applicable local electrical and plumbing codes (and tools necessary to confirm proper installation and operation of the water heater) as they relate to the installation of electric water heaters. The service agency must have a thorough understanding of the water heater Instruction Manual.

GENERAL SAFETY

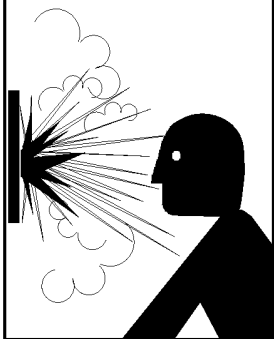

	<p>⚠ WARNING</p> <p>Read and understand this instruction manual and safety messages before installing, operating, or servicing this water heater.</p> <p>Failure to follow these instructions and safety messages could result in death or serious injury.</p> <p>This manual must remain with water heater.</p>
---	---

<p>CAUTION</p> <p>Improper installation and use may result in property damage.</p>
<ul style="list-style-type: none"> • Do not operate water heater if flood damaged. • Inspect and replace anode. • Install in location with drainage. • Fill tank with water before operation. • Be alert for thermal expansion. <p>Refer to this manual for installation and service.</p>

	<p>⚠ WARNING</p> <p>Explosion Hazard</p>
	<ul style="list-style-type: none"> • Overheated water can cause water tank explosion. • Properly sized temperature and pressure relief valve must be installed in opening provided.

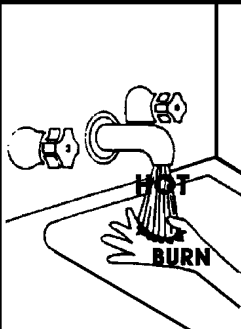
	<p>⚠ WARNING</p>
	<ul style="list-style-type: none"> • Before removing any access panels or servicing the water heater, make sure the electrical supply to the water heater is turned "OFF." • Failure to do this could result in death, serious bodily injury, or property damage.

<p>⚠ DANGER</p>	<p>Water temperature over 125°F (52°C) can cause severe burns instantly resulting in severe injury or death.</p> <p>Children, the elderly, and the physically or mentally disabled are at highest risk for scald injury.</p> <p>Feel water before bathing or showering.</p> <p>Temperature limiting valves are available.</p> <p>Read this instruction manual for safe temperature setting.</p>
	

<p>⚠ WARNING</p> <p>Fire Hazard / Electric Shock Hazard</p>		
	<ul style="list-style-type: none"> • Do not use this water heater with any voltage other than shown on the model rating plate. • Failure to use the correct voltage shown on the model rating plate could result in death, serious bodily injury, or property damage. 	

INTRODUCTION

Thank You for purchasing this water heating system. Properly installed and maintained, it should give you years of trouble free service.

Abbreviations Found In This Instruction Manual:

- ANSI - American National Standards Institute
- ASME - American Society of Mechanical Engineers
- GAMA - Gas Appliance Manufacturers Association
- NEC - National Electrical Code
- NFPA - National Fire Protection Association
- UL - Underwriters Laboratories Inc.

SYSTEM DESCRIPTION

This Solar Water Heating System consists of four main parts — the solar collectors, the solar pump station, the solar storage tank, and the plumbing for the heat transfer fluid.

The solar pump station uses a pump to circulate a heat-transfer fluid through the “collector loop”. This collector loop includes the solar collectors, the fluid lines or “line-set” and a heat exchanger. The collector loop is a “closed loop”, meaning there is no contact of the heat transfer fluid with your potable water or with the atmosphere. The collector loop contains only a small volume of heat-transfer fluid which is non-toxic and freeze-protected to -30°F (Freeze tolerance limits are based upon an assumed set of environmental conditions). Though freeze protection may not be necessary in all areas, the heat-transfer fluid also contains corrosion inhibitors which protect the system components, has an elevated boiling point, and is suitable throughout North America.

When exposed to sunlight, the solar collectors get hot. As the heat-transfer fluid passes through the collectors, it absorbs the heat and then travels down the line-set to the tank. The hot fluid passes through the heat exchanger and heat is transferred to the potable water. After giving up its heat to the potable water, the cool heat-transfer fluid is pumped back to the solar collectors to be heated again. Hot potable water is stored in the solar storage tank.

The auxiliary or back-up electric-heating guarantees hot water even under poor solar conditions (at night or when very cloudy). The minimum acceptable temperature set-point is specified in local plumbing codes.

You can save the most money on your water-heating bills by using the backup heater on your system as little as possible. If the sun shines brightly between 10 am and 3 pm, enough heat will normally be generated to keep the water hot throughout the rest of the day and night.

However, on days when the sky is cloudy or when large quantities of hot water are being used, we recommend leaving the backup heater turned on and set to 120° F to provide adequate hot water.

PREPARING FOR THE INSTALLATION

1. Read the “General Safety” section of this manual first and then the entire manual carefully. If you don’t follow the safety rules, the water heater will not operate properly. It could cause DEATH, SERIOUS BODILY INJURY, AND/OR PROPERTY DAMAGE.

This manual contains instructions for the installation, operation, and maintenance of the solar water heater. It also contains warnings throughout the manual that you must read and understand. All warnings and all instructions are essential to the proper operation of the water heater and your safety. **READ THE ENTIRE MANUAL BEFORE ATTEMPTING TO INSTALL OR OPERATE THE WATER HEATER.**

2. The installation must conform with these instructions and the local code authority having jurisdiction and the requirements of the power company. In the absence of local code requirements follow NFPA-70, the National Electrical Code (current edition), which may be ordered from: National Fire Protection Association, 1 Batterymarch Park, Quincy, MA 02269.
3. If after reading this manual you have any questions or do not understand any portion of the instructions, call the local utility or the manufacturer whose name appears on the rating plate.
4. Carefully plan your intended placement of the water heater and collectors. **INSTALLATION OR SERVICE OF THIS WATER HEATER REQUIRES ABILITY EQUIVALENT TO THAT OF A LICENSED TRADESMAN IN THE FIELD INVOLVED. PLUMBING AND ELECTRICAL WORK ARE REQUIRED.**

Examine the location to ensure the water heater complies with the “Facts to Consider About the Location” section in this manual.

5. For California installation this water heater must be braced, anchored, or strapped to avoid falling or moving during an earthquake. See instructions for correct installation procedures. Instructions may be obtained from California Office of the State Architect, 400 P Street, Sacramento, CA 95814.
6. Massachusetts Code requires this water heater to be installed in accordance with Massachusetts 248-CMR 2.00: State Plumbing Code and 248-CMR 5.00.

TABLE OF CONTENTS

SAFE INSTALLATION, USE AND SERVICE.....	2
Important Definitions	2
GENERAL SAFETY	3
INTRODUCTIONS	4
System Description	4
Preparing for Installation	4
TABLE OF CONTENTS	5
SYSTEM DIAGRAM/TYPICAL INSTALLATION	6
SYSTEM COMPONENT PART	7
STORAGE TANK INSTALLATION	7
Local Codes	7
Temperature-Pressure Relief Valve	7
Closed System/Thermal Expansion.....	8
Locating the Solar Water Heater	8
Water Piping	8
Installation in Residential Garages.....	9
Filling the Solar Water Heater with Water	9
Wiring of Element	9
Thermostat	10
Temperature Regulation	10
Temperature Settings	10
Temperature Adjustment	10
Draining	11
Element	12
Anode	12
Water Heater Sounds	12
SOLAR COLLECTOR INSTALLATION	13
Collector Location	13
General Considerations	13
Collector Orientation	14-15
Spanner Mounting	15
Lag Bolt Mounting	16
Attaching Collector to Mounting Brackets	17
Collector Piping	18
Collector Piping Detail	19
Sensor Mounting at Collector	19
Piping Through the Roof	19
Piping Insulation	19
Preparation of the Heat Transfer Fluid	19
PUMP STATION INSTALLATION	20
Pump Station	20
Safety Instructions	20
Safety Equipment	21
Plumbing Configuration	22
Function	22
Flowmeter	23
Start-up and Operation of the Solar Pump Station	23
Leak Detection	23
Flushing	23
Filling	24
Draining.....	24
PUMP STATION CONTROL INSTRUCTIONS	25
Control Instructions	25
Operation and Function	25-30
TROUBLESHOOTING	31-33
SYSTEM MAINTENANCE	34
REPAIR PARTS	35

SYSTEM DIAGRAM/TYPICAL INSTALLATION

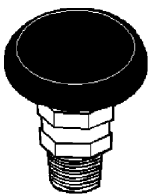
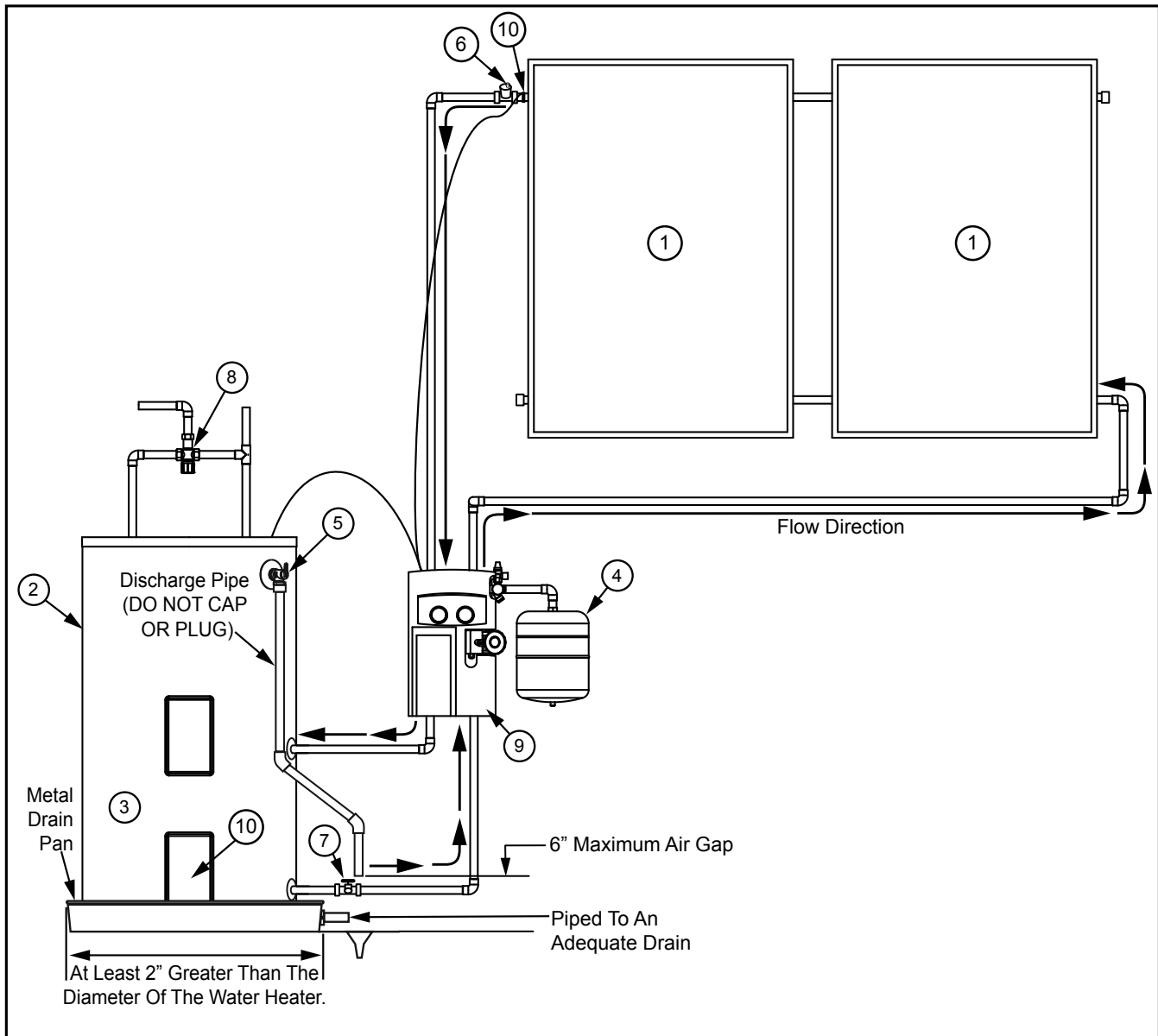

INSTALL VACUUM RELIEF IN COLD WATER INLET LINE AS REQUIRED BY LOCAL CODES.

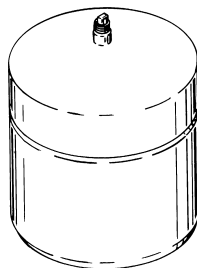

INSTALL THERMAL EXPANSION TANK OR DEVICE IF WATER HEATER IS INSTALLED IN A CLOSED WATER SYSTEM.

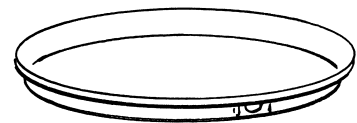

INSTALL SUITABLE METAL DRAIN PANS UNDER HEATERS TO PREVENT DAMAGE DUE TO LEAKAGE. REFER TO WATER HEATER LOCATION, SEE "LOCATING THE SOLAR WATER HEATER" SECTION.

Figure 1.

SYSTEM COMPONENT PART

TABLE 1:		
Item	Component	Function
1	Solar collector	Absorbs the sun's heat energy and transfers this to the heat transfer fluid circulating through the collector
2	Solar storage tank	Stores potable water heated by solar generated heat or installed back-up electric resistance element
3	Heat exchanger (Not Shown)	Transfers the heat from the collector loop to the potable water in the solar storage tank
4	Expansion tank	Allows for the expansion and contraction of the heat transfer fluid as it heat and cools.
5	Temperature and Pressure relief valve	Required by plumbing code to automatically open and dump water if the storage tank exceeds 150 PSI of pressure or 210° F in temperature
6	Air vent	Purges air from the collector loop fluid during the installation and is shut off later on to prevent glycol losses in steam phase.
7	Drain valve	Used to drain the heat transfer fluid from the collector loop
8	Mixing valve	Used to temper hot water from the solar storage tank with cold inlet water to maintain appropriate temperature hot water delivered from the system
9	Solar pump station	Controls the flow of heat transfer fluid from the collectors to the tank/ heat exchanger. For a detailed description of the solar pump station see page 20.
10	Temperature sensor	Tank and collector sensor work together to turn the circulating pump(s) on and off at preset temperature differentials

STORAGE TANK INSTALLATION

Never operate the electrical heating element without being certain the solar water heater is completely filled with water. If any air is left in the top of the tank, the heating element will burn out.

LOCAL CODES

The installation of this solar water heater must be in accordance with these instructions and all applicable local codes and electric utility requirements. In the absence of local codes, install in accordance with the latest edition of the National Electrical Code (NFPA-70).

TEMPERATURE-PRESSURE RELIEF VALVE

For protection against excessive pressures and temperatures in this water heater, install temperature-pressure protective equipment required by local codes, but not less than a combination temperature-pressure relief valve certified by a nationally recognized testing laboratory that maintains periodic inspection of production of listed equipment or materials, as meeting the requirements for Relief Valves for Hot Water Supply Systems, the latest edition of ANSI Z21.22. This valve must be marked with a maximum set pressure not to exceed the marked hydrostatic working pressure of the water heater (150 lbs./sq. in.).

Install the temperature-pressure relief valve directly into the fitting of the water heater. Position the valve downward and provide a discharge pipe that must terminate a maximum of six inches above a floor drain or external to the building.

In cold climates, it is recommended that the discharge pipe be terminated at an adequate drain inside the building. Be certain that no contact is made with any live electrical part. The discharge opening must not be blocked or reduced in size under any circumstances. Excessive length, over 15 feet, or use of more than two elbows can cause restriction and reduce the discharge capacity of the valve.

No valve or other obstruction is to be placed between the temperature-pressure relief valve and the tank. Do not connect tubing directly to discharge drain unless a 6" air gap is provided. To prevent bodily injury, hazard to life or damage to property, the temperature-pressure relief valve must be allowed to discharge water in quantities should circumstances demand. If the discharge pipe is not connected to a drain or other suitable means, the water flow may cause property damage.

The Discharge Pipe:

- Shall not be smaller in size than the outlet pipe size of the temperature-pressure relief valve, or have any reducing couplings or other restrictions.
- Shall not be plugged or blocked.
- Shall be of material listed for hot water distribution.
- Shall be installed so as to allow complete drainage of both the temperature-pressure relief valve, and the discharge pipe.
- Must terminate a maximum of six inches above a floor drain

or external to the building. In cold climates, it is recommended that the discharge pipe be terminated at an adequate drain inside the building.

- Shall not have any valve between the relief valve and tank.

When installing the temperature-pressure relief valve, use two or three turns of teflon tape or other suitable thread sealer around the threaded end of the valve.

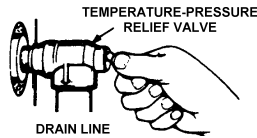

Figure 2

The temperature-pressure relief valve should be manually opened once a year. Caution should be taken to ensure that (1) no one is in front of or around the outlet of the temperature-pressure relief valve discharge line, and (2) the water manually discharged will not cause any bodily injury or property damage because the water may be extremely hot.

If after manually operating the valve, it fails to completely reset and continues to release water, immediately close the cold water inlet to the water heater, follow the draining instructions, and replace the temperature-pressure relief valve with a new one.

If the temperature-pressure relief valve on the appliance weeps this may be due to thermal expansion. The water supply serving this solar water heater may have a check valve installed. Contact the water supplier or local plumbing contractor on how to control this situation. Do not plug the temperature-pressure relief valve.

CLOSED SYSTEM/THERMAL EXPANSION

As water is heated, it expands (thermal expansion). In a closed system, the volume of water will grow. As the volume of water grows, there will be a corresponding increase in water pressure due to thermal expansion. Thermal expansion can cause premature tank failure (leakage). This type of failure is not covered under the limited warranty. Thermal expansion can also cause intermittent temperature-pressure relief valve operation: water discharged from the valve due to excessive pressure build up. The temperature-pressure relief valve is not intended for the constant relief of thermal expansion. This condition is not covered under the limited warranty.

A properly-sized thermal expansion tank should be installed on all closed systems to control the harmful effects of thermal expansion. Contact a plumbing service agency or your retail supplier regarding the installation of a thermal expansion tank..

LOCATING THE SOLAR WATER HEATER

If you have a choice of where to install the solar water heater, these ideas may help you decide.

1. Put the solar water heater indoors as close as possible to where you use the most hot water. This water heater

is not intended for outdoor installation.

2. It is handy to have a floor drain, tub or sink nearby. That will make it easy to drain water from the water heater. It is also a good place to end the drain line of the temperature-pressure relief (T & P) valve.
3. The solar water heater or the pipes and the connections may, in time, leak. Put the solar water heater in a place where a water leak will not damage anything.
4. You must not put the water heater in an area where it might freeze. You must turn off the electricity to the water heater before you drain it, to protect the heating elements.
5. Make sure that you are able to reach the drain valve and all access panels when the water heater is in place. This will make it easy to service the water heater.
6. The water heater must be level before you begin the piping.

WATER HEATERS EVENTUALLY LEAK. The installation of the water heater must be accomplished in such a manner that if the tank or any connections should leak, the flow of water will not cause damage to the area adjoining the water heater or to lower floors of the structure. When such locations can't be avoided, a suitable metal drain pan should be installed under the water heater. Such a pan should be no greater than 1 1/2 inches deep, have a minimum length and width of at least two inches greater than the heater dimensions and must be piped to an adequate drain.

This solar water heater, as all water heaters, will eventually leak. Do not install without adequate drainage provisions where water flow will cause damage. Note: normal condensation from a solar water heater may appear to be a leaking tank.

WATER PIPING

This solar water heater is design certified to be used with a potable water system. When connecting water piping with solder joints use only lead free solder.

A diagram showing a hand reaching for a hot water tap. The tap is labeled 'HOT' and the hand is labeled 'BURN'. A warning sign with a triangle and the word 'DANGER' is in the top left corner.	<p>▲ DANGER Untempered hot water can cause severe burns instantly resulting in severe injury or death.</p> <p>Children, elderly, and the physically or mentally disabled are at highest risk for scald injury.</p> <p>Feel water before bathing or showering.</p> <p>Temperature limiting valves are available.</p>
---	--

The indirect coil in this unit is a single wall and may only be used in a closed loop - fill only with a mixture of propylene glycol containing corrosion inhibitors (such as Dowfrost™ HD) (50% by volume maximum) and distilled or de-mineralized water. Never fill with a toxic liquid. Use of any heat transfer fluid other than that specified or failure to operate the heat exchanger in a closed loop will void the warranty, and may result in poor performance, equipment damage, or risk to health and safety.

This solar water heater shall not be connected to any heating systems or component(s) previously used with a non-potable water heating appliance.

If this solar water heater is also used for space heating applications, all piping and components connected to the solar water heater shall be suitable for use with potable water.

This appliance has been design certified as a solar water heater complying with Standards for Safety - UL174 for the U.S. and can/csa-c22.2 No 110 F379.1 and F379.2 for Canada. The particular application of this appliance described (above paragraph) may be subject to review and approval by local code officials.

Toxic chemicals such as used for treatment of boilers or non-potable water heating appliances shall never be introduced into a potable water space heating system.

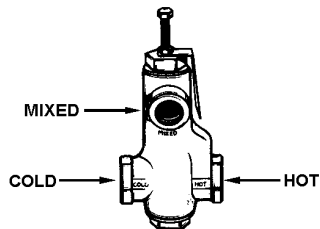
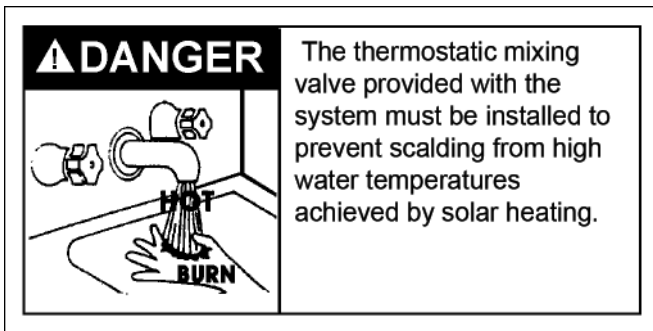

Figure 3

The solar water heater will work better if you keep the hot water runs short. You will also get hot water faster and with less heat loss.

The illustration shows the correct valves and fittings that you will need to install the solar water heater. Threaded (3/4") water connections are supplied through the tank top.

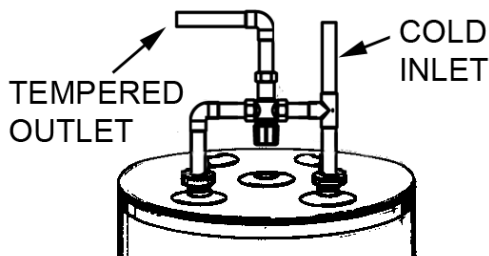

Figure 4

1. Buy the fittings that you need to connect the pipes. Remember that you have to connect both the hot and cold water pipes.
2. Apply a light covering of pipe joint compound to each outside thread before making connection.

3. Connect the cold water supply pipe to the cold water inlet of your solar water heater as follows:
 - a. Look at the top cover of the solar water heater. The hot and cold connections are marked there.
 - b. A non-metallic dip tube is supplied to carry cold water from the tank top to the bottom. Be sure that it is in the cold water inlet.
 - c. If using copper tubing, solder tubing to an adapter BEFORE you attach the adapter to the cold water inlet. DO NOT solder the cold water supply pipe directly to the cold water inlet connection. It might harm the dip tube.
 - d. The cold water supply line must have a shut-off valve and union.
4. Use a union to connect the hot water supply pipe to the solar water heater's hot water outlet.

Operating an empty or partially filled solar water heater will result in damage to the tank.

If a solar water heater is installed in a closed water system; such as one having a back flow preventer, check valve or water meter with check valve in the cold water supply line, means shall be provided to control thermal expansion. Contact the water supplier or local plumbing contractor on how to control this situation.

INSTALLATION IN RESIDENTIAL GARAGES

The solar water heater must be located and/or protected so it is not subject to physical damage by a moving vehicle.

FILLING THE SOLAR WATER HEATER WITH WATER

1. Close the solar water heater drain valve. The drain valve is on the lower front of the solar water heater.
2. Open the cold water supply to the solar water heater. NOTE: THIS VALVE MUST BE LEFT OPEN WHEN THE SOLAR WATER HEATER IS IN USE.
3. Fill the solar water heater until a constant flow of water runs out an opened hot water faucet. This will let out air in the solar water heater and the piping. Close the faucet after all air has been purged and the water comes out with constant flow.. You must not turn the electricity on until the solar water heater is full of water. IF ANY AIR IS LEFT IN THE TOP OF THE SOLAR WATER HEATER, THE TOP HEATING ELEMENT WILL BURN OUT IMMEDIATELY.
4. Check all the new water piping for leaks. Fix as needed.

WIRING OF ELEMENT

Determine voltage and wattage from the rating plate attached to the solar water heater. All external wiring, connection, and overcurrent protective devices must be provided and installed in accordance with the latest edition of the National Electrical Code, local codes, and local utility requirements. The solar water heater must be electrically "grounded" by the installer. A green ground screw has been provided on the solar water heater's junction box.

The grounding electrode conductor shall be of copper, aluminum, or copperclad aluminum. The material shall be resistant to corrosion, and shall be of one continuous length without a splice or joint.

Rigid metal conduit, intermediate metal conduit, or electrical metallic tubing may be used for the grounding means if conduit or tubing is terminated in fittings approved for grounding.

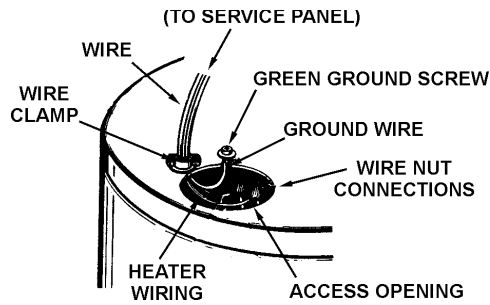

Figure 5

Flexible metal conduit or flexible metallic tubing shall be permitted for grounding if all the following conditions are met:

1. The length in any ground return path does not exceed 6 feet.
2. The circuit conductors contained therein are protected by overcurrent devices rated at 20 amperes or less.
3. The conduit or tubing is terminated in fittings approved for grounding.

Never use this solar water heater unless it is completely full of water.

SOLAR WATER HEATERS EQUIPPED FOR ONE TYPE VOLTAGE ONLY. This solar water heater is equipped for one type of voltage only. Check the rating plate near the bottom access panel for the correct voltage. **DO NOT USE THIS SOLAR WATER HEATER WITH ANY VOLTAGE OTHER THAN THE ONE SHOWN ON THE MODEL RATING PLATE.** Failure to use the correct voltage can cause problems which can result in **DEATH, SERIOUS BODILY INJURY OR PROPERTY DAMAGE.** If you have any questions or doubts consult your electric company.

If wiring from the fuse box or circuit breaker box was aluminum for the old tank, replace it with copper wire. If you wish to reuse the existing aluminum wire, have the connection at the solar water heater made by a competent electrician. Contact your local utility to arrange for a professional electrician.

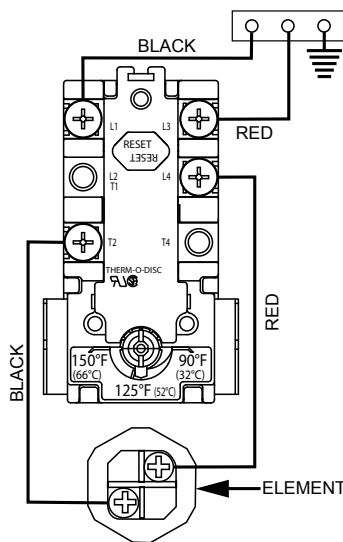

Figure 6

THERMOSTAT

Each thermostat is factory preset at 120°F to reduce the risk of scald injury. This setting has proven by experience to be most satisfactory from the standpoint of operational costs and household needs.

Solar water heaters installed in Florida require the thermostat(s) to be set at 125°F. If you wish to adjust the settings, see the "Temperature Adjustment" section of this installation manual on page 11.

TEMPERATURE REGULATION

⚠ DANGER	<p>Untempered hot water can cause severe burns instantly resulting in severe injury or death.</p> <p>Children, elderly, and the physically or mentally disabled are at highest risk for scald injury.</p> <p>Feel water before bathing or showering.</p> <p>Temperature limiting valves are available.</p>

HOTTER WATER CAN SCALD: Solar water heaters are intended to produce hot water. Water heated to a temperature which will satisfy clothes washing, dish washing, and other sanitizing needs can cause scalds resulting in serious personal injury and/or death. Some people are more likely to be permanently injured by hot water than others. These include the elderly, children, the infirmed, or physically handicapped. If anyone using hot water in your home fits into one of these groups or if there is a local code or state law requiring a certain temperature water at the hot water tap, then you must take special precautions. Please see Figure 7 and Table 2 for information regarding thermostat settings. In addition to using the lowest possible temperature setting that satisfies your hot water needs, some type of mixing device, such as a mixing valve should be used at the hot water taps used by these people or at the solar water heater. Mixing valves are available at plumbing supply or hardware stores. Follow manufacturers instructions for installation of the valves. Before changing the factory setting of the thermostat, read the Temperature Adjustment section. **KEEPING THE THERMOSTAT SETTING AT 120°F WILL REDUCE THE RISK OF SCALDS.** Never allow small children to use a hot water tap, or to draw their own bath water. Never leave a child or handicapped person unattended in a bathtub or shower.

TEMPERATURE SETTINGS

NOTE: This residential solar water heater will not supply sanitizing hot water for dishwashers.

The thermostat is factory set at its lowest position which approximates 120°F and is adjustable if a different water temperature is desired. For best system savings this temperature should not be changed. Read all warnings in this manual and on the solar water heater before proceeding.

TEMPERATURE SETTINGS

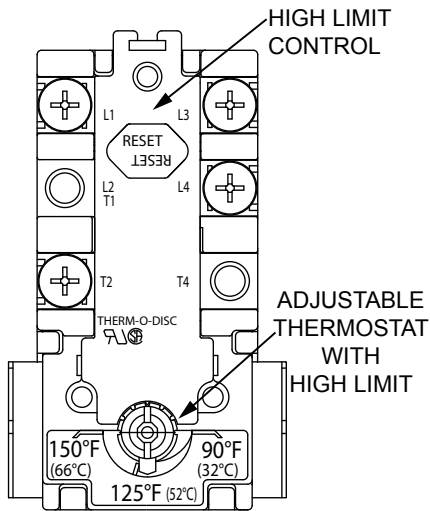

Figure 7

Water Temperature °F	Time for 1st Degree Burn (Less Severe Burns)	Time for Permanent Burns 2nd & 3rd Degree (Most Severe Burns)
110	(normal shower temp.)	
116	(pain threshold)	
116	35 minutes	45 minutes
122	1 minute	5 minutes
131	5 seconds	25 seconds
140	2 seconds	5 seconds
149	1 second	2 seconds
154	instantaneous	1 seconds

(U.S. Government Memorandum, C.P.S.C., Peter L. Armstrong, Sept. 15, 1978)

TEMPERATURE ADJUSTMENT

To adjust the temperature setting:

1. Turn "OFF" the electrical power to the water heater, at the junction box.

HAZARD OF ELECTRICAL SHOCK! Failure to turn "OFF" electric power to the solar water heater will result in the possibility of DEATH, SERIOUS BODILY INJURY OR PROPERTY DAMAGE.

2. Take off the access panel and fold away the insulation.
3. Turn the water temperature dial clockwise (↻) to increase the temperature, or counterclockwise (↺) to decrease the temperature.
4. Fold the insulation back in place and replace the access panel.
5. Turn "ON" the power supply.

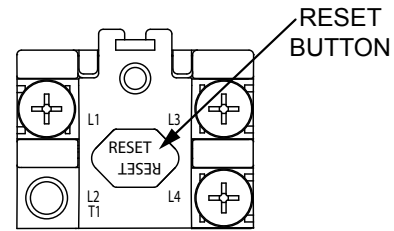

Figure 8

A non-adjustable high temperature limit control operates before steam temperatures are reached. The high limit is in the same area as the upper thermostat and must be reset manually when it activates. BECAUSE THE HIGH LIMIT ACTIVATES ONLY WHEN ABNORMALLY HIGH WATER TEMPERATURES ARE PRESENT, IT IS IMPORTANT THAT A QUALIFIED SERVICE AGENT BE CONTACTED TO DETERMINE THE REASON FOR OPERATION BEFORE RESETTING.

TANK SENSOR

The surface mount tank sensor should be attached to the sensor stud behind the lower door by placing the hole in the sensor over the stud provided and securing in place with a nut. The end of the tank sensor shall be connected to the red wires in the opening with wire nuts (with no regard for polarity). The other ends of the red temperature sensor extension extend from the top of the tank and shall be connected to the controller in the tank sensor position.

DRAINING

It is recommended that the storage tank be drained and flushed every 6 months to remove sediment which may build up during operation. The water heater should be drained if being shut down during freezing temperatures. To drain the tank, perform the following steps:

1. Turn off power to the water heater.
2. Open a nearby hot water faucet until the water is no longer hot.
3. Close the cold water inlet valve.
4. Connect a hose to the drain valve and terminate it to an adequate drain or external to the building.
5. Open the water heater drain valve and allow all of the water to drain from the tank. Flush the tank with water as needed to remove sediment.
6. Close the drain valve, refill the tank, and restart the heater as directed in this manual.

If the water heater is going to be shut down for an extended period, the drain valve should be left open.

IMPORTANT: Condensation may occur when refilling the tank and should not be confused with a tank leak.

If the solar water heater is to be shut off and exposed to freezing temperatures, it must be drained. Water, if left in the tank and allowed to freeze, will expand and damage the solar water heater.

1. Turn "OFF" the electrical supply to the solar water heater.

Make sure the electrical supply to the solar water heater is turned OFF. Failure to heed this will result in the possibility of DEATH, SERIOUS BODILY INJURY OR PROPERTY DAMAGE.

2. Open a nearby hot water faucet until the water is no longer hot, then turn off the cold water supply and open the drain valve, leaving the hot water faucet open.
3. The drain valve must be left open during the shut-down period. Once the solar water heater is drained close the hot water faucet.

ELEMENT

In some water areas, scale or mineral deposits will build up on heating elements. This build up may cause a rumbling noise. Follow the element replacement directions to remove the elements from the tank. Soaking in vinegar and scraping will remove the mineral deposit. Be careful not to bend the element.

ELEMENT REPLACEMENT

Replacement elements must (1) be the same voltage and (2) no greater wattage than listed on the model and rating plate affixed to the solar water heater.

1. Turn OFF the electrical supply to the solar water heater. Make sure the electrical supply to the solar water heater is turned OFF. Failure to heed this will result in the possibility of DEATH, SERIOUS BODILY INJURY OR PROPERTY DAMAGE.
2. Drain the solar water heater. Follow the directions for draining.
3. Take off the access panel and take off the access panel and remove the insulation. Disconnect the wires from the heating element terminals.
4. Use an element wrench to remove the element and gasket. You should always use a new gasket when you replace the element.
5. Install new element.
6. Reconnect the wires as they were.
7. Fill the tank, following the filling directions on page 9. Fill the tank completely with water, BEFORE you turn on the electric supply.

ANODE

Each water heater contains at least one anode rod, which will slowly deplete (due to electrolysis) prolonging the life of the water heater by protecting the glass-lined tank from corrosion. Adverse water quality, hotter water temperatures, high hot water usage, hydronic heating devices, and water softening methods can increase the rate of anode rod depletion. Once the anode rod is depleted, the tank will start to corrode, eventually developing a leak.

Certain water conditions will cause a reaction between the anode rod and the water. The most common complaint associated with the anode rod is a "rotten egg smell" produced from the presence of hydrogen sulfide gas dissolved in the water. **IMPORTANT:** Do not remove this rod permanently as it may void any warranties. A special anode rod may be available if water odor or discoloration occurs. **NOTE:** This rod may reduce but not eliminate water odor problems. The water supply system may require special filtration equipment from a water conditioning company to successfully eliminate all water odor problems.

Artificially softened water is exceedingly corrosive because the process substitutes sodium ions for magnesium and

calcium ions. The use of a water softener may decrease the life of the water heater tank.

The anode rod should be removed from the water heater tank every 3 years for inspection. **NOTE:** artificially softened water requires the anode rod to be inspected annually.

The following are typical (but not all) signs of a depleted anode rod:

- The majority of the rod's diameter is less than 3/8".
- Significant sections of the support wire (approx. 1/3 or more of the anode rod's length) are visible.

If the anode rod shows signs of either or both it should be replaced. **NOTE:** Whether re-installing or replacing the anode rod, check for any leaks and immediately correct if found.

In replacing the anode:

1. Turn off power supply to the water heater.
2. Shut off the water supply and open a nearby hot water faucet to depressurize the water tank.
3. Drain approximately 5 gallons of water from tank. (Refer to "Draining and Flushing" for proper procedures). Close drain valve.
4. Remove old anode rod.
5. Use Teflon® tape or approved pipe sealant on threads and install new anode rod.
6. Turn on water supply and open a nearby hot water faucet to purge air from water system. Check for any leaks and immediately correct any if found.
7. Restart the water heater as directed in this manual. See the Storage Tank Repair Parts section for anode rod location.

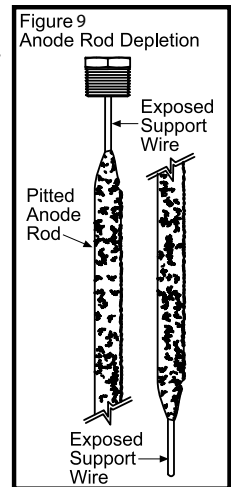

TEFLON® is a registered trademark of E.I. Du Pont De Nemours and Company.

Hydrogen gas can be produced in a hot water system that has not been used for a long period of time (generally two weeks or more). Hydrogen gas is extremely flammable and explosive. To prevent the possibility of bodily injury under these conditions, open the hot water faucet for several minutes at the kitchen sink before any electrical appliances which are connected to the hot water system are used (such as a dishwasher or washing machine). If hydrogen gas is present, there will probably be an unusual sound similar to air escaping through the pipe as the hot water faucet is opened. There must be no smoking or open flame near the faucet at the time it is opened.

WATER HEATER SOUNDS

1. The solar water heater is equipped with an immersion heating element for fastest recovery. If the solar water heater occasionally makes noises this is not a defect or a safety hazard.
2. Lime or scale has accumulated on the heating element causing a hissing sound. Element scale removal can be accomplished by using vinegar or by scraping.

SOLAR COLLECTOR INSTALLATION

COLLECTOR LOCATION

Proper location and orientation of the solar collectors is important for maximum system efficiency. The collectors should be unshaded from 10:00 am through 3:00 pm each day in every month of the year and should be located as close to the storage tank as possible to minimize heat loss in the piping runs. The best orientation is achieved when the collectors are facing due south +/- 45°

and tilted at an angle from the horizontal equal to the latitude of the location + 15°. A steeper angle provides better winter performance as the sun is lower in the sky. The collectors will also shed snow more effectively at the steeper angle. Figure 10 below shows many alternatives for collector mounting. Placing the collectors as close as possible to the peak of the roof will make installation easier by providing increased attic access.

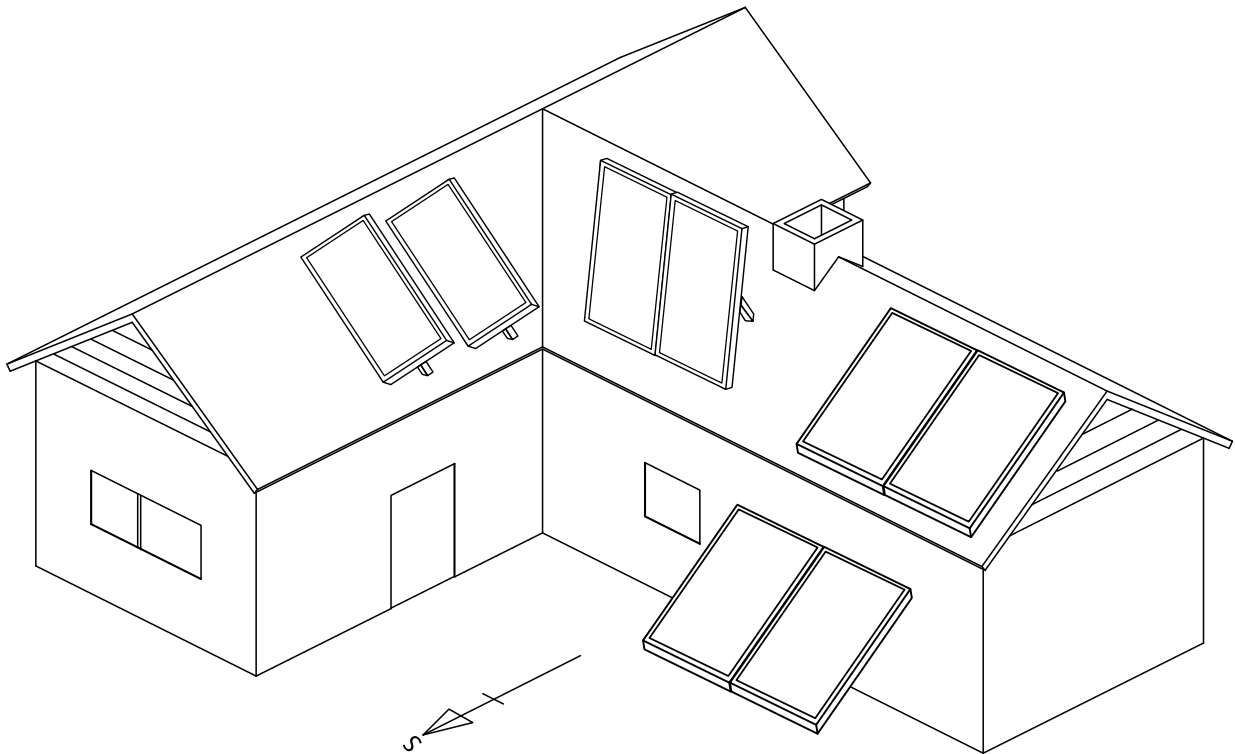

Figure 10

GENERAL CONSIDERATIONS

The contractor shall obtain all required permits and approvals.

The installation shall conform to all federal, state and local regulations, codes, ordinances and standards governing solar water heating system installations and the contractor shall adhere to sound building safety and trade practices. Special consideration must be given to building code requirements for the penetration of structural members and fire rated assemblies.

Ensure the mounting surface is solid and able to withstand in excess of 330lbs / 150kg of pull force

that may be encountered during high winds. Consult a structural engineer if in doubt.

The solar collector must be located in a structurally sound area of the roof that will be unshaded for the majority of the day all year round. Adjacent buildings and trees should be checked for possible winter shading. An instrument such as the Solar Pathfinder (www.solarpathfinder.com) can be used for solar site analysis.

Before the installation the contractor shall inspect the condition of the roof and notify the homeowner of any existing roof damage or necessary repairs.

SOLAR COLLECTOR INSTALLATION

COLLECTOR ORIENTATION

Proper tilt angle for solar collectors is latitude plus 15°. This 15° additional tilt improves performance in the winter, when the sun is weaker and at a lower angle. The cost in performance in the summer when the sun is high is overcome by the hours of sunlight and strength of irradiation that occurs in the summer. Tilt mounting accessory kits are available to set the proper collector angle. Please call your local dealer for more information.

When the collectors are mounted one behind the other, they should be spaced sufficiently apart so that when the sun is at its lowest altitude, the collectors will not shade each other and cause efficiency loss (see Figure 13). If a collector must be installed horizontally, replace the upper vent with rubber plug as shown below, in order to prevent rain penetration (see Figures 11 & 12).

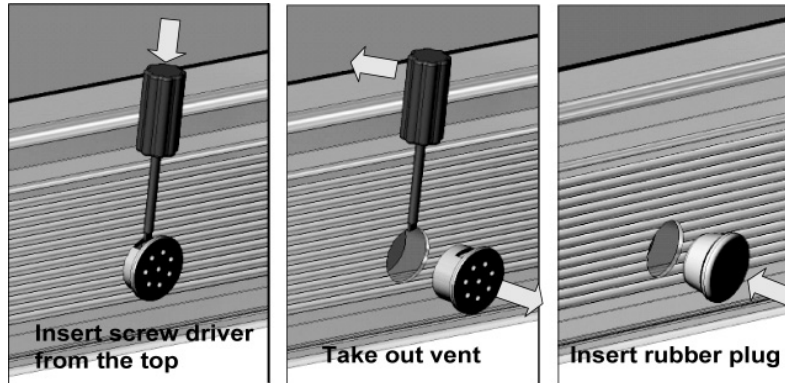

Figure 11

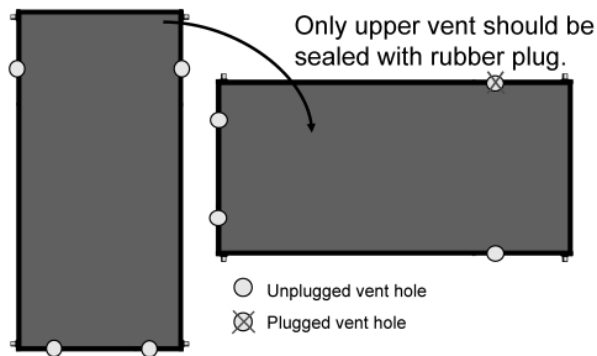

Figure 12

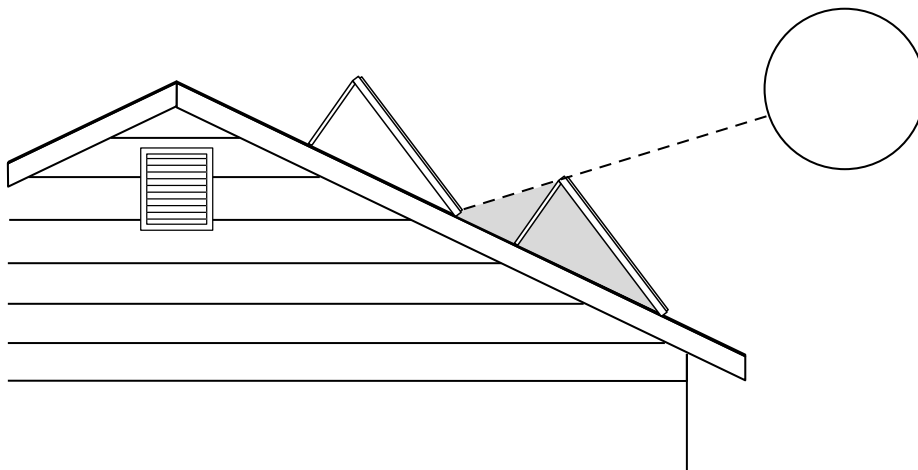

Figure 13

All persons working on roofs should have successfully completed a fall-safety course and should be properly equipped with appropriate safety equipment.

⚠ WARNING

After completion of the collector mounting and prior to system charging the collectors must be covered by a blanket or other means to avoid solar radiation from heating the collectors. The surfaces of the collector can become extremely hot and could pose a burn hazard

The most important structural consideration is to securely anchor the solar collector and the mounting hardware to the structural members of the roof with the stainless steel

hardware provided. The solar collector must be attached to the mounting hardware as detailed in Figure 17.

Preserving the integrity of the roof membrane is the most important roofing consideration. Ensure that all roof penetrations required to plumb and mount the solar collector are properly flashed and sealed in accordance with standard roofing practices.

If the region is subject to hurricane conditions, additional steps may be required to secure the collector and mounting hardware to the structural members. In certain areas of the country, local building codes may require collector wind load testing or prescribe specific mounting procedures. Consult your local building department.

Install the collectors as described in the Spanner Mounting instructions.

SPANNER MOUNTING

In spanner mounting after the mounting feet are positioned correctly, a 3/8" hole is drilled between the rafters (see Figures 15 and 16 for placement of drill holes). Roof sealant is applied between the hardware provided and the roof. The bracket is then positioned over the 3/8" hole using sealant between the bracket and the roof. A piece of stainless steel 3/8" all-thread is then inserted through the hole. A washer and nut secures the all-thread to the bracket (be sure to apply sealant/caulk underneath the washer and on top of the nut). The all-thread rod should extend about 4"

below the roof rafters. Drill a 3/8" hole in a 2" x 4" piece of lumber and insert the all-thread rod through it. The 2" x 4" should span 2 rafters. With a lockwasher and fender washer secure the all-thread to the 2" x 4". Tighten down until the bracket is tightly secured to the roof. Be careful not to over-tighten and dish out the roof underneath the bracket. For best results insert a spacer block next to the all-thread that is the width of the rafter to avoid deformation of the roof. (See Figure 14)

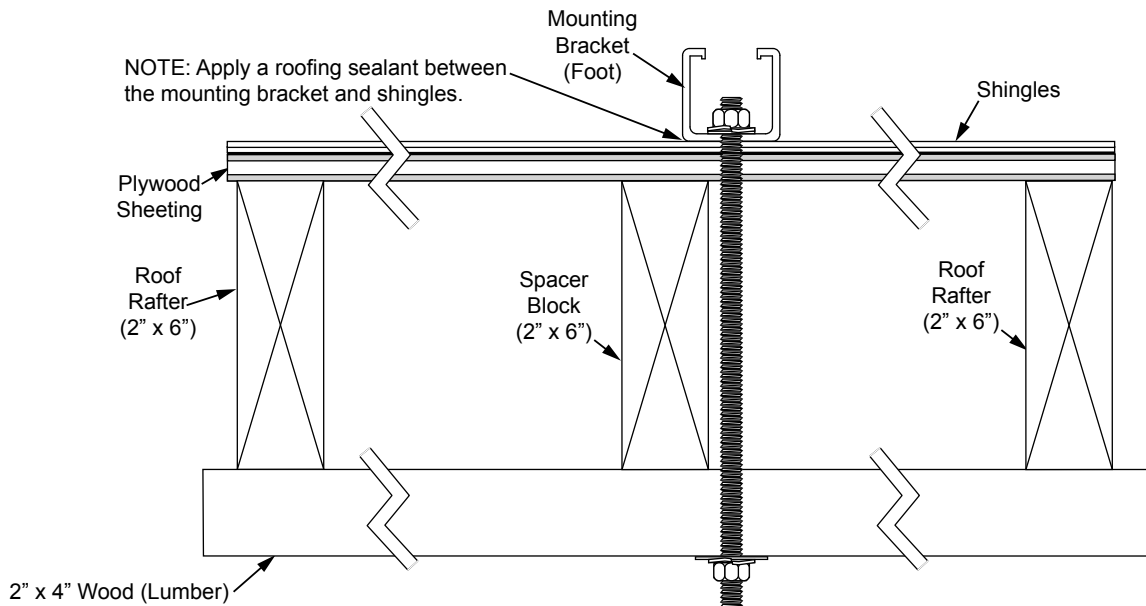

Figure 14

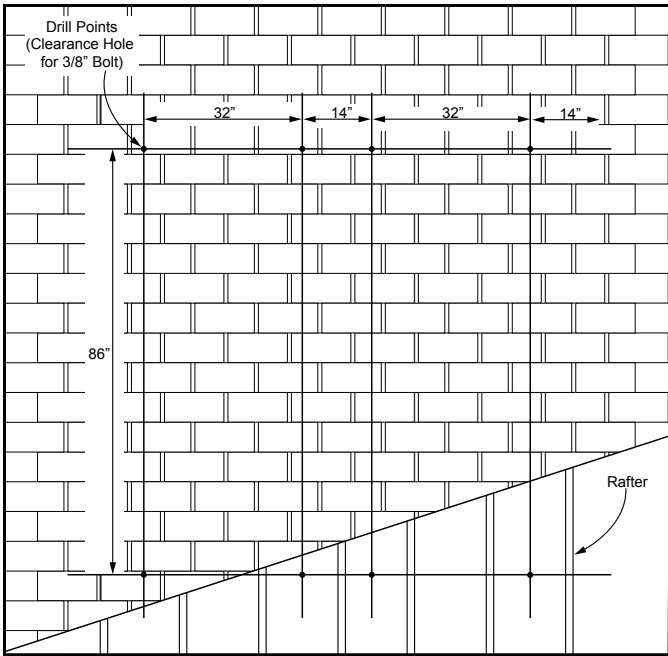

Figure 15

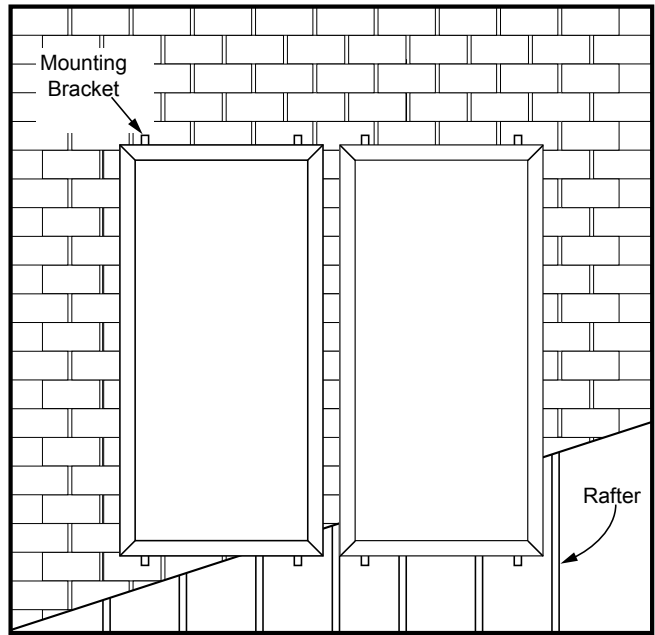

Figure 16

ATTACHING COLLECTOR TO MOUNTING BRACKETS

Once all of the mounting brackets have been secured to the roof insert the channel nut with spring inside the channel. Then fasten the collector mounting clip to the nut with the stainless steel bolt using a flat washer and lock washer – refer to Figure 17.

To aid in handling the collectors on the roof the collector mounting clips may be tightened to the lower mounting brackets prior to raising the collectors. The collector can then be set on the mounting brackets against the clip while the top clips are fastened over the lip on the collector. The bottom clips can then be loosened and retightened over the collector lip.

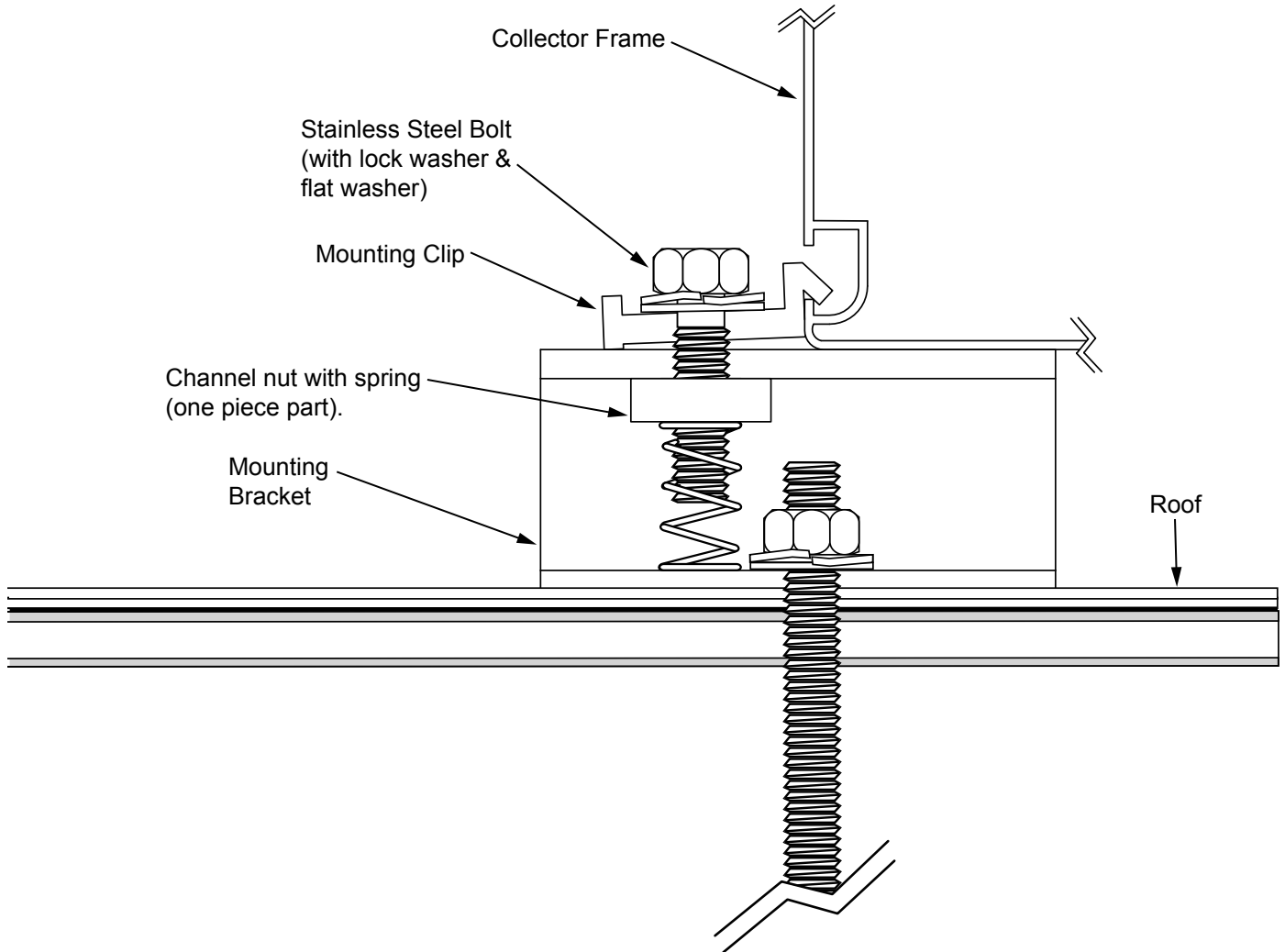

Figure 17

COLLECTOR PIPING

The piping of the system should be considered before a final decision is made on how the collectors are mounted. Piping should be made of copper tube of the type meeting local codes, insulated with Armacell UT Solaflex or similar. The maximum total piping length allowed in this system is 200 equivalent ft.

Use only lead-free solder. Use of 50/50 lead solder is expressly prohibited. Use of galvanized steel, CPVC, PVC, PEX or any other type of plastic pipe is prohibited.

Care should be taken in the spacing of collectors as attachment of piping is easiest with properly aligned collectors. The connection between the collector panels is made with copper unions. To aid in installation the collector array layout should be planned on the ground and the unions soldered to the adjoining headers prior to lifting the collectors to the roof. Similarly the top and bottom outside header that will not be used for the inlet or outlet (should be on opposite sides) should be capped with the 1" copper cap provided while on the ground. (See Figure 18 for details.)

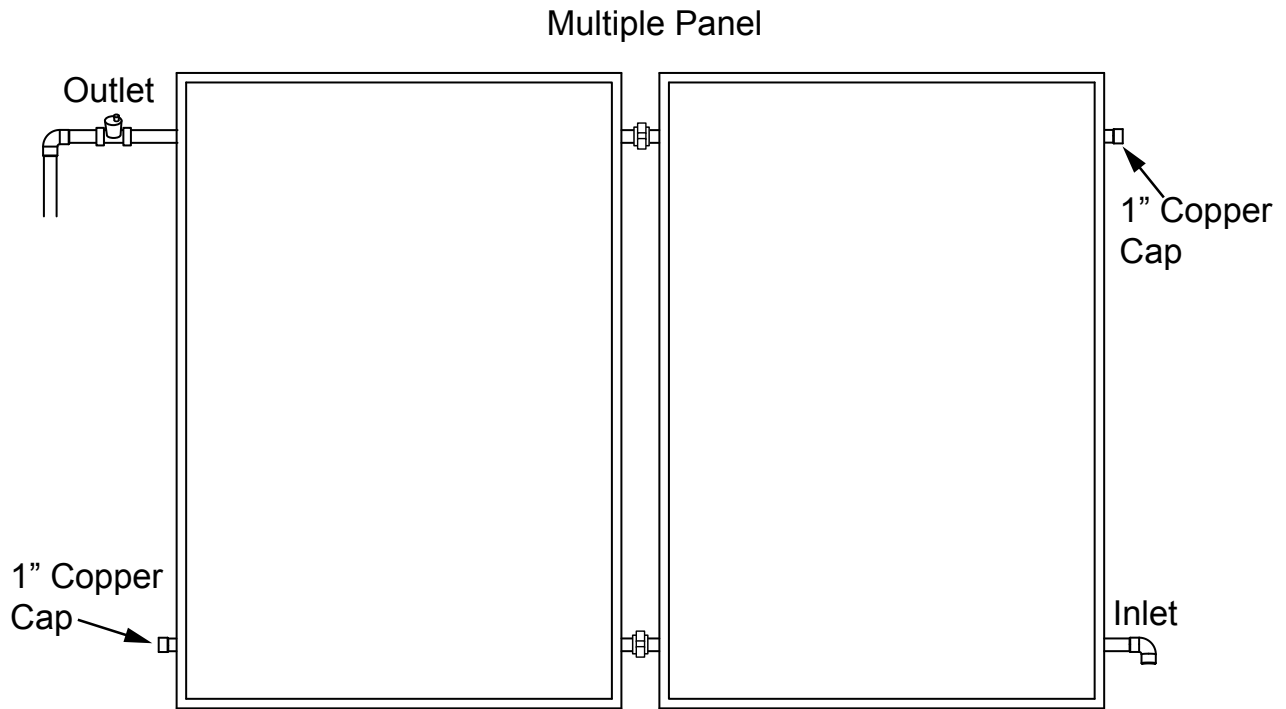

Figure 18

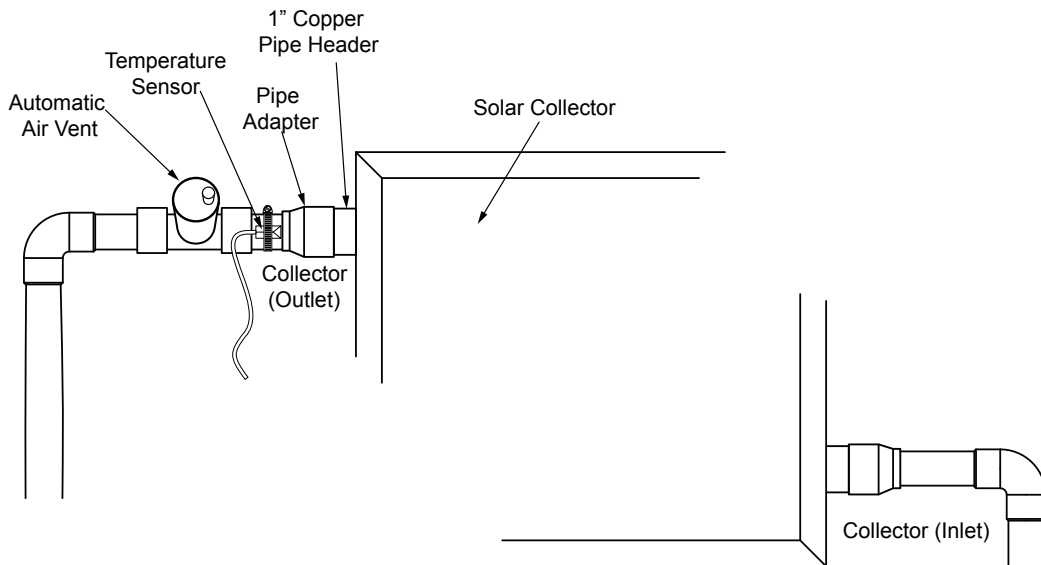

Figure 19

COLLECTOR PIPING DETAIL

The outlets of the collector are 1" copper pipe nipples (Figure 19). They should be piped as shown with provisions for an automatic air vent. The air vent must be oriented vertically as this must be the highest point in the system in order for air to escape. This will prevent air lock and subsequent loss of system efficiency. Teflon tape or high temperature, high quality pipe sealant should be used when making threaded connections.

The collector inlets should be piped similarly but without the automatic air vent.

SENSOR MOUNTING AT COLLECTOR

The angled collector heat sensor is mounted to the outlet of the collector (Figure 20). The stainless steel screw clamp should be used. The entire sensor should be wrapped thoroughly with the insulating stretch tape so that the sensor is isolated from the outside air. If possible route the sensor wire through the roof flashing and connect the sensor wire to the sensor extension wire provided with wire nuts.

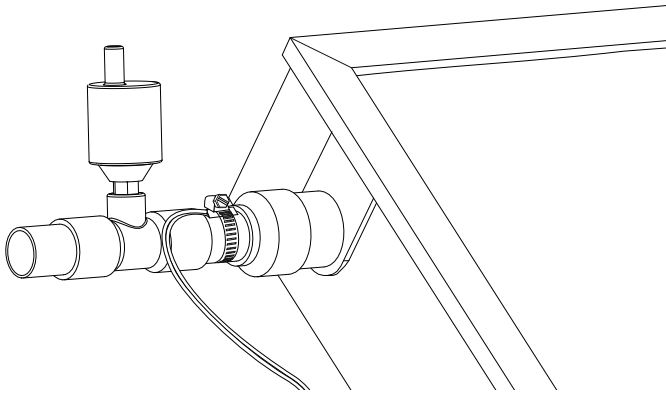

Figure 20

PIPING THROUGH THE ROOF

Piping through the roof should be weatherproofed as shown in Figure 21. Three-quarter inch holes are drilled through the roof on the same plane as the supply and return header pipes. Do not drill the hole above the supply header of the collector. This will prevent the collector from draining. Placing the hole below the supply header is acceptable, but it is more aesthetic if it is located on the same plane. The flashing plate is placed over the hole with its base cemented and nailed to the roof and its upper edges slid under the adjoining shingle. A hole 1/2 the diameter of the supply tube should be cut in the top of the flashing gasket and the copper tube supply and return line is then pushed up through the hole in the flashing. The same procedure is then repeated for the return line and flashing. The sensor wire should also be run through the return flashing by piercing a small hole in one of the corner nipples. Caution - making the hole for the copper pipe or the sensor wire too big will prevent a proper seal. The return and supply lines should be supported under the roof to prevent undue stress on the piping assemblies at the collector.

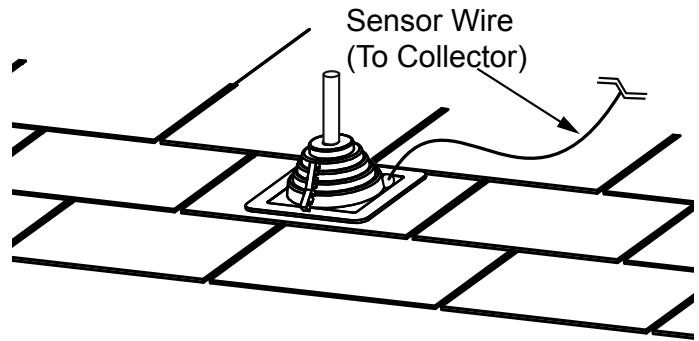

Figure 21

PIPE INSULATION

The collector loop piping (exterior and interior) must be well insulated with a high quality flexible EPDM closed cell insulation to minimize heat loss. The wall thickness of the pipe insulation should not be less than 3/4". A 1" wall thickness is required in all areas prone to annual hard freeze conditions. When it comes to pipe insulation the rule is simple: thicker is better. The specified insulation material is Armacell UT Solaflex or equivalent.

To the extent possible, slide the insulation material over the pipe without cutting or taping. All butt joints must be sealed with high temperature contact adhesive. The use of rigid polyethylene pipe insulation is prohibited. All outdoor insulation should be protected from moisture and Ultraviolet deterioration by either paint or foil tape. Insulation to complete the outdoor portion of the installation has been provided.

PREPARATION OF THE HEAT TRANSFER FLUID

Pour 100% Propylene Glycol into a large clean bucket. Add an equivalent amount of distilled or de-mineralized water for a 50/50 solution by volume.

The use of regular tap water as a mixing agent is prohibited. Distilled or de-mineralized water is often available from grocery stores and drugstores. This solution provides freeze protection down to -30° F and burst protection down to -60° F.

Use of heat-transfer fluid other than a maximum 50/50 mix by volume of Propylene Glycol and distilled or de-mineralized water is not permitted. Use of any heat-transfer fluid other than that specified by the appliance manufacturer will void warranty, and may result in poor performance, equipment damage, or risk to health and safety.

PUMP STATION INSTALLATION

PUMP STATION

The following instructions describe the installation, start-up, function and operation of the solar pump station. The solar pump station may only be used in the collector circuit of a solar thermal installation. The technical data specified in these instructions must be observed. Improper usage excludes any liability claims.

The wrapping materials that form the outer shell of the pump station are made of recyclable materials and can be disposed of with recyclable materials.

The solar station is a premounted valves and fittings group checked for leakage used to circulate the solar fluid in the solar circuit.

SAFETY INSTRUCTIONS

The installation and start-up of the solar station as well as the connection of electrical components require technical knowledge commensurate with a recognized vocational qualification as a fitter for plumbing, heating and air conditioning technology, or a profession requiring a comparable level of knowledge [specialist]. The following must be observed during installation and start-up:

- Relevant local and national codes
- Accident prevention regulations of the professional association
- Instructions and safety instructions mentioned in this manual

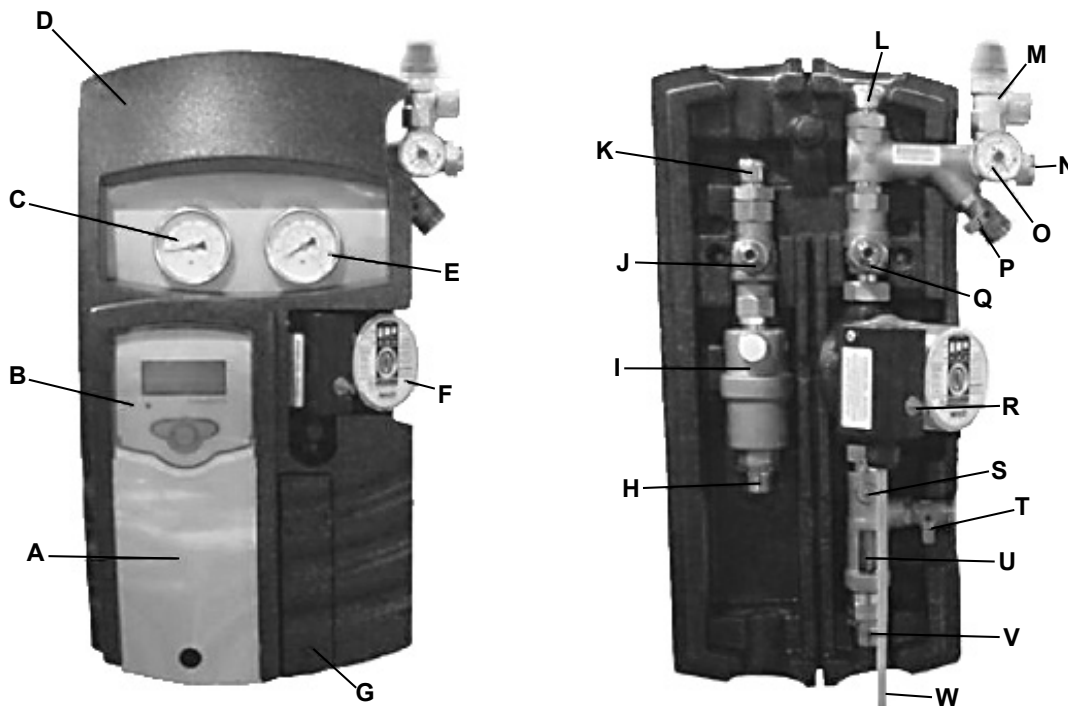

Components:

A	Controller cover	M	Pressure relief valve
B	Differential temperature controller	N	Connection for expansion tank
C	Temperature gauge (red) with immersion sleeve for insertion into the return ball valve	O	Pressure gauge
D	Front cover	P	Fill valve
E	Temperature gauge (blue) with immersion sleeve for insertion into the supply ball valve	Q	Supply isolation ball valve with integrated check valve
F	Circulation pump	R	Pump speed selector
G	Flow meter access door	S	Flow restrictor
H	Supply (storage tank)	T	Drain valve
I	Airstop	U	Flowmeter
J	Return isolation ball valve with integrated check valve	V	Return (storage tank)
K	Return (collector loop)	W	Power Cord
L	Supply (collector loop)		

Figure 22

PUMP STATION INSTALLATION

SAFETY EQUIPMENT

For protection against excessive pressures in the collector loop a pressure relief valve is integrated into the solar pump station. Drain tubing must be installed in the valve outlet so that any discharge will exit only within 6 inches above, or at any distance below the structural floor. Be certain that no contact is made with any live electrical part. The discharge opening must not be blocked or reduced in size under any circumstances. Excessive length, over 15 feet, or use of more than two elbows can cause restriction and reduce the discharge capacity of the valve.

Do not connect tubing directly to discharge drain unless a 6" air gap is provided. To prevent bodily injury, hazard to life, or damage to property, the relief valve must be allowed to discharge fluid in quantities should circumstances demand. If the discharge pipe is not connected to a drain or other suitable means, the fluid may cause property damage.

ATTENTION: TO PREVENT DAMAGE TO PROPERTY, THE LOCATION OF INSTALLATION MUST BE DRY, LOAD-CARRYING AND FROST-PROOF TO PREVENT MATERIAL DAMAGE TO THE INSTALLATION.

Mounting the solar pump station to the wall

1. Choose the position to install the solar pump station next to the storage tank (noting that the tank solar loop inlet (from collector) and outlet (to pump) are on the right side of the tank)
2. Remove the temperature gauges (C,E) by grasping the frame and pulling straight forward.
3. Remove the front cover (D) of the solar station.
4. Remove the retainer clips behind the isolation ball valves (J, Q) with a flat head screw driver to free the mounting plate from the station (see Figure 23).

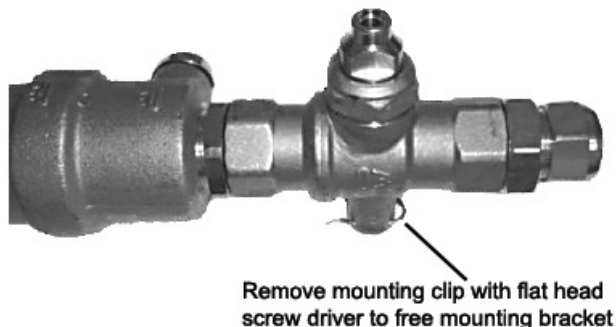

Figure 23

Note: To aid in later assembly, while each leg of the station assembly is removed from the bracket, an extension leg of 3/4" copper tubing can be attached to the bottom threaded connector using the 3/4" female NPT sweat adaptor provided.

5. Line the mounting plate up level on the wall and mark the drill holes. (Holes will be 5 3/4" (146 mm) apart). Drill the two holes with a 3/8" drill bit and mount the plate with either the masonry mounting hardware or drywall hardware provided.
6. After the mounting plate is secured to the wall replace the solar pump station back cover, insert the retaining clips half way onto the mounting retaining stud (see Figure 24) behind the isolation ball valves (J, Q), push the assembly onto the bracket mounting stud and push the clip down into place. Ensure assembly is properly locked into place.



Figure 24

7. Connect the stainless steel corrugated hose to the safety group (N). Do not forget to insert the seal.
8. Choose the position for the expansion tank bracket on the wall beside the solar pump station. Fasten the bracket to the wall with the enclosed hardware (masonry or drywall).
9. Unscrew the tank connector to separate the two halves. The top half should be pushed onto the mounting bracket and the lock ring tightened. The bottom half should be attached to the 3/4" threads on the expansion tank.

NOTE: The tank connector allows you to isolate the expansion tank from the solar circuit (Figure 25). When the nut is unscrewed the valves in each half of the tank connector are automatically closed tightly by the integrated springs. Each side remains closed until the two halves are screwed back together and the valves are forced open.

The expansion tank should not be connected to the system until it has been flushed and charged.

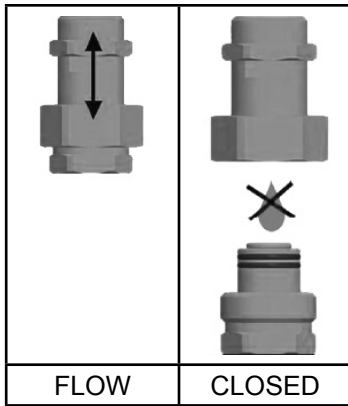

Figure 25

10. Check and set the pressure of the air bladder in the expansion tank to 25 psi. If the pressure is higher bleed pressure out until it is correct. If the pressure is too low add air by use of a compressor or bicycle pump until the pressure is correct.
11. Plumb the solar pump station to the storage tank and to the collector: The tank connections should use $\frac{3}{4}$ " copper pipe and can be connected using the threaded adaptors provided. The collector connections should use $\frac{1}{2}$ " copper pipe and can be connected with the the compression fittings provided.

The total piping run in the solar loop should not exceed 200 equivalent feet. Failure to limit the line length may cause poor system performance and lead to premature pump failure.

12. Add the supplied copper drain valve to the lowest point in the collector loop (near the tank by the bottom coil outlet labeled "to pump" in most cases)

Installing the $\frac{1}{2}$ " copper to and from the collector using the compression fittings.

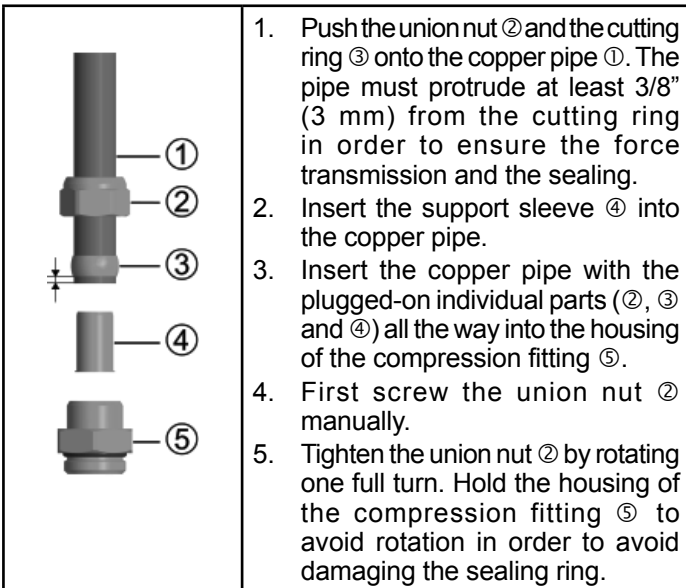

Figure 26

PLUMBING CONFIGURATION

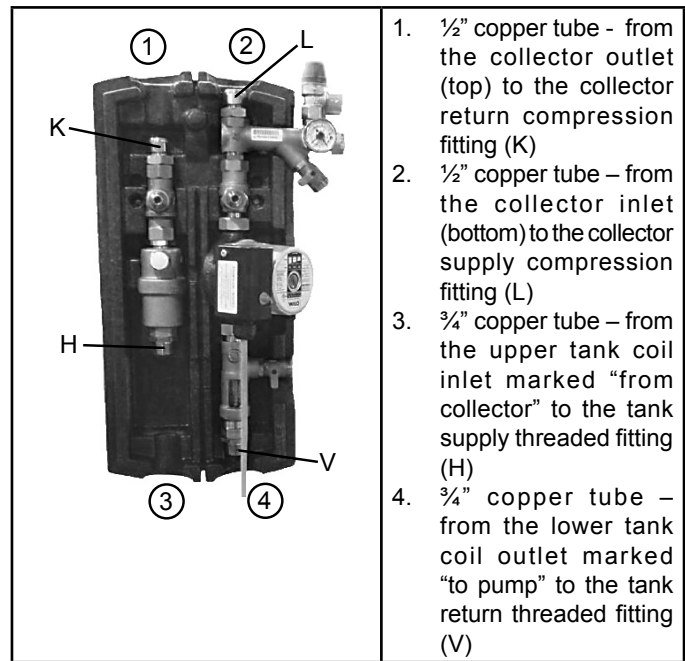

Figure 27

FUNCTION

Check valves

The solar station is equipped with check valves in the supply and the return ball valve (J, Q).

For filling, venting and flushing of the installation the check valves must be turned to the correct position. To set the proper position for the check valves take off the temperature gauges (C, E), remove the top cover (D) and turn the ball valves into the proper position using a wrench (see Figure 28). In the 45° position the balls in the ball valves push the check valves open.

During operation the ball valves must be in 0° position.

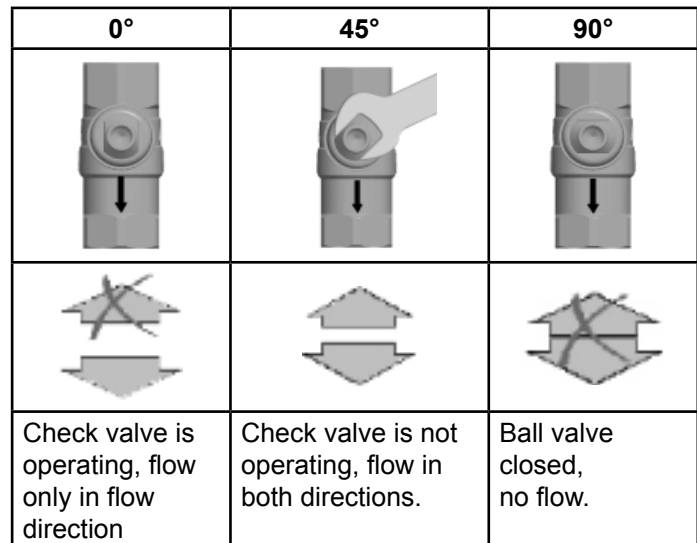

Figure 28

FLOWMETER

The flowmeter (U) serves to measure and display flow volume of the system in a range of 0.5-3.5 US gpm.

It has an integrated restrictor (S) with adjustment valve which allows fine adjustment of the flow volume of the solar installation.

In order to guarantee the flawless function of the measuring device the installation must be flushed and free from foreign substances.

The flowmeter **MUST** be mounted vertically.

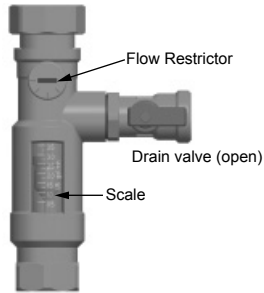

Figure 29

Always use a flat head screwdriver to adjust the flowmeter.

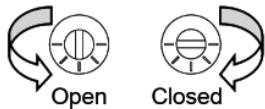

Figure 30

Read the flow rate from the upper edge of the floating body.

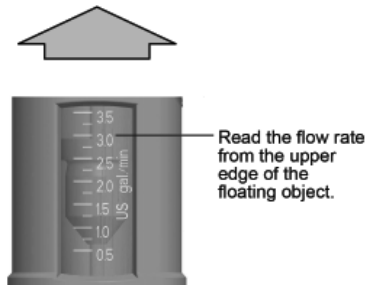
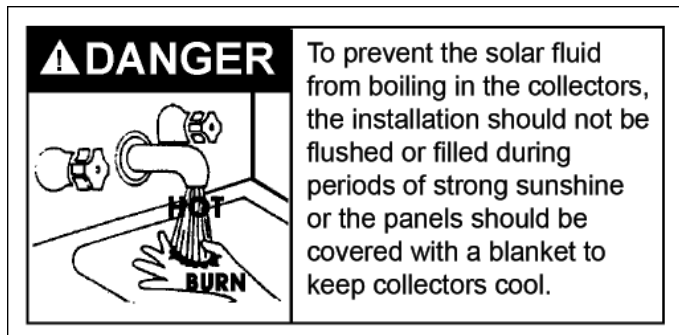

Figure 31

START-UP AND OPERATION OF THE SOLAR PUMP STATION

Observe the following safety instructions when starting-up the solar thermal installation:



LEAK DETECTION

1. Disconnect the expansion tank from the solar system by unscrewing the nut on the tank connector. This prevents the access of dirt particles present in the pipes from entering the expansion tank.
2. Remove the temperature gauges (C, E) and the front cover (D) of the solar pump station.
3. Turn the two isolation ball valves (J, Q) to 45° using an appropriate wrench to allow flow in both directions.
4. Close the drain valve (T).
5. Close the automatic airvent at the collector array (turn the cap clockwise by hand until tight).
6. Connect an air pressure hose to the fill valve (P) below the pressure gauge (O) and open this valve.
7. Using an air compressor or pressurized air tank fill the system with pressurized air until the pressure gauge (O) reads 40 psi then close the fill valve (P).
8. The pressure should hold steady for 15 minutes. If the pressure falls it is an indication of a leak. Find and repair the leak then repeat steps 6 and 7 watching for the pressure to hold at least 15 minutes. After the pressure test slowly open the drain valve (T) to release the air pressure on the system.

FLUSHING

CAUTION

Solar thermal installations cannot be completely emptied after flushing. There is a danger of frost damage if water is used for flushing. Only use water to flush the system when the outside temperature is above 32° F, otherwise use the solar fluid to flush making sure to filter any debris before final filling.

Use a water / propylene glycol mixture as a solar fluid (maximum 50% propylene glycol).

9. Disconnect the air pressure hose from the fill valve (P)
10. Connect a water hose from a water source with at least 40 PSI supply pressure to the fill valve (P).
11. Connect a discharge hose to the drain valve (T) and open this valve. Place the other end of the discharge hose into an appropriate drain.
12. Turn the supply ball valve (Q) to 90° (horizontal) so that the valve is closed.
13. Turn the slot of the flow restrictor (S) to the horizontal position using a flat head screwdriver. The integrated ball valve is now closed and will prevent debris from entering the pump.

14. Turn on the supply water and open the fill valve (P) then leave running for 15 minutes to flush debris out of the solar loop
15. After the 15 minute flush turn off the supply water at the source and allow the system to drain. When water stops flowing out of the discharge hose close the fill valve (P)
16. Close the drain valve (T) on the pump station and move this hose to the drain valve that was installed at the lowest point of the solar loop (near the bottom of the tank)
17. Open this drain valve with a flat head screw driver and open the fill valve (P) slowly to vent the system and allow the remaining water to drain out. In order to vent the system completely it is necessary to open the flow restrictor (S) - turn with flat head screwdriver until vertical.

FILLING

18. Close the lower loop drain valve with a flat head screw driver and move the discharge hose from the lower valve to the drain valve (T) on the pump station and open this valve. The other end of the discharge hose will be placed into the glycol solution container.
19. Turn the return ball valve (J) to 0° (vertical) so that flow is only allowed in the proper direction.
20. Connect a fill hose from the glycol container to a 1/2 HP transfer pump and another hose from the transfer pump to the fill valve (P) then open this valve.
21. Open the cap on the automatic air vent at the top of the collector array 3 full turns counterclockwise to vent any air in the solar loop (do not remove cap completely).
22. In order to flush as much air as possible from the system, turn on the transfer pump to fill the system with the glycol solution and allow to circulate for 15 minutes or until no bubbles are returning to the collector.
23. Remove the cap from the front of the airstop (I) and open the vent with a flat head screwdriver. This will release air that has been captured by the system during circulation. Cover small outlet port with a rag as fluid will be ejected after the air is evacuated.
24. Turn the supply ball valve (Q) to 0° (vertical) so that flow is only allowed in the proper direction and ensure that the flow restrictor (S) is completely open (vertical)
25. With the transfer pump still running close the drain valve and allow to system to rise to an operating pressure of 30 psi on the pressure gauge then close the fill valve and turn off the pump. If the pressure has exceeded 30 psi after the pump is off then slowly open the drain valve and relieve pressure until the pressure gauge reads 30 psi, then close the drain valve.
26. Remove the fill and drain hoses and close the fill and drain valves (P,T) with the caps provided.

27. Plug in the solar pump station to a 115V outlet and turn the pump on using the manual mode (see Pump Station Control Instruction section).
28. Adjust the pump speed using the pump speed selector (R) to the lowest setting possible to set the system flow rate equal to or higher than the final system flow rate. If the flow rate is higher than necessary turn the flow restrictor (S) on the flowmeter with a flat head screwdriver to reduce the flow to the actual required:
 - 2 panel system: 1.4 gpm
 - 3 panel system: 2.1 gpm

Cycle the pump on and off in manual mode to check whether the starting torque is sufficient with the pump speed selected. If flow does not start properly a higher speed may need to be selected and the flow reset to the proper level with the flow restrictor (S) Again check the installation for leaks and ensure both ball valves are open completely.

29. Replace the front cover (D) and re-insert the red temperature gauge (C) in the return ball valve (J) and the blue temperature gauge (E) in the supply ball valve (Q).
30. Set the controller to operate in automatic mode (see Pump Station Control Instruction section).
31. After the system has been running for several days the cap on the automatic air vent at the top of the collector array should be closed by turning the cap counterclockwise by hand until tight.

DRAINING

1. Open the check valves in the supply and the return ball valves (J,Q) by turning the ball valves to position 45° with an appropriate wrench
2. Place a temperature-resistant container under the drain valve at the lowest point of the solar thermal installation (usually near heat exchange coil at the bottom of the tank).

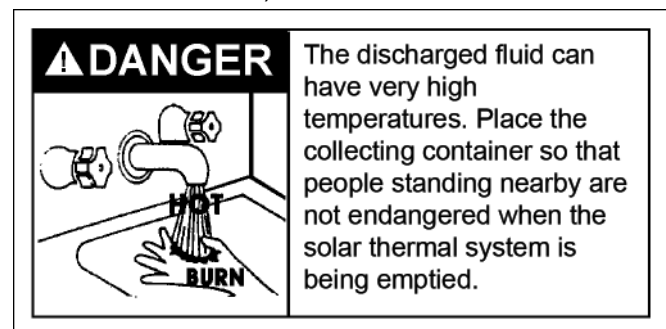

3. Open the drain valve at the lowest point of the solar thermal installation.
4. Open the automatic air vent at the top of the collector array 3 full turns counterclockwise by hand (cap should not be completely removed). This will serve as a vacuum break to aid in draining.
5. Dispose of the solar fluid observing any local code.

PUMP STATION CONTROL INSTRUCTIONS

CONTROL INSTRUCTIONS

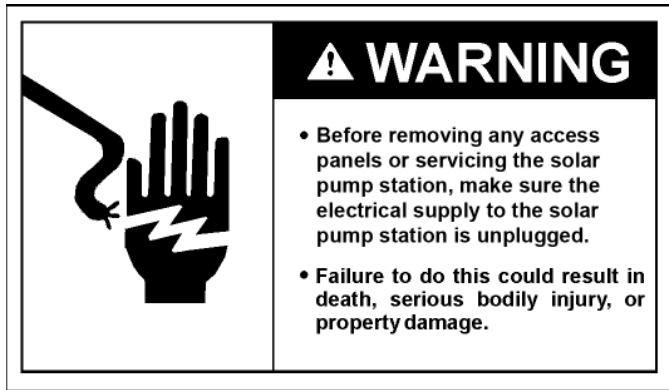

Prior to operation of the control on the solar pump station the collector and tank temperature sensors must be properly connected. Remove the control cover and connect the sensors to the proper terminals.

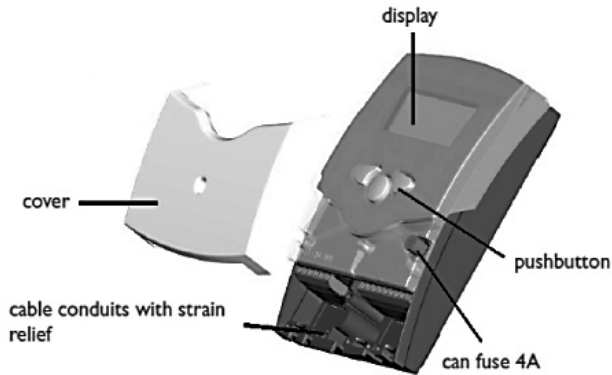

Figure 32

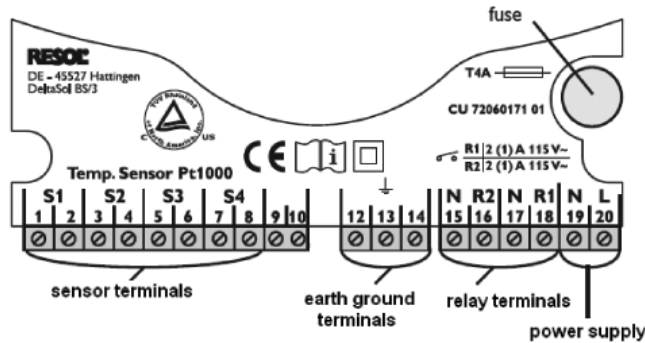

Figure 33

The temperature sensors should be connected to the following terminals with no dependence on polarity:

- 1 / 2 = sensor 1 (collector outlet)
- 3 / 4 = sensor 2 (tank bottom)
- 5 / 6 = sensor 3 (tank top – optional, not included)
- 7 / 8 = sensor 4 (return flow temperature – optional, not included)

The power supply is connected to the following terminals:

- 19 = Neutral - N
- 20 = Line power - L
- 12 = Ground (⊕)

The control is equipped with two relays, one for the integrated pump in the solar pump station and one for use in specialty custom applications requiring a second pump:

- Relay 1 (primary pump)
 - 18 = Line power - R1
 - 17 = Neutral - N
 - 13 = Ground (⊕)
- Relay 2 (secondary pump – optional, not included)
 - 16 = Line power - R2
 - 15 = Neutral - N
 - 14 = Ground (⊕)

OPERATION AND FUNCTION

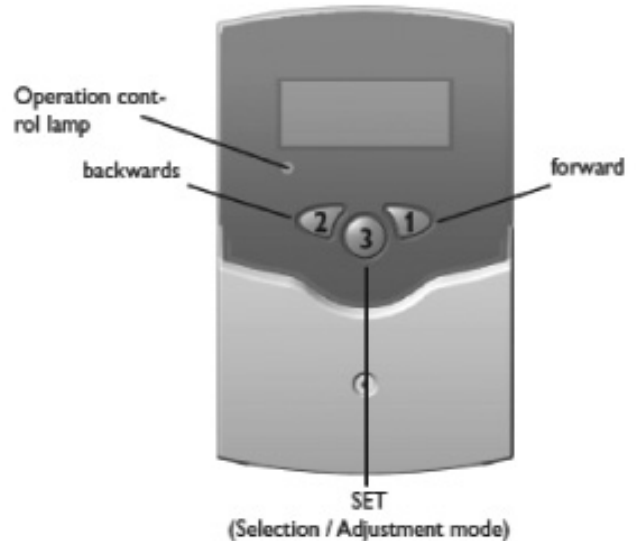
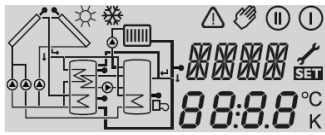

Figure 34

The controller is operated by 3 pushbuttons below the display. The forward key (1) is used for scrolling forward through the indication menu or to increase the adjustment values. The backwards key (2) is used for scrolling backward through the indication menu or to decrease the adjustment values.

For system settings adjustment press the forward key to reach the last display channel. Then hold the forward button down for 2 seconds and the system setting screens can then be shown. If an adjustable value is shown on the display **SET** is indicated. To change the set value press the Set button (3) so that **SET** flashes. Adjust the value using button 1 or 2 until the desired value is shown then press button 3 so that **SET** permanently appears. The adjusted value is now saved.

System Monitoring Display



Complete monitoring display

The system monitoring display consists of 3 blocks: channel indication, the toolbar, and system screen.

Channel indication



The channel indication consists of two lines. The upper line is an alphanumeric 16 segment indication in which the channel name or menu item is shown. The lower 7 segment indication shows the channel value and the adjustment parameters are indicated.

Temperatures are indicated in °F / °C, Temperature differences are indicated in °F / K

Toolbar



The symbols in the toolbar indicate the current system status

SYMBOL	STANDARD	FLASHING
	Relay 1 active	
	Relay 2 active	
	Maximum tank limit reached / maximum tank temperature exceeded.	Collector cooling function active
	Antifreeze – function activated	Collector minimum temperature reached
		Collector security shutdown or tank security shutdown active (max temperature reached).
		Sensor error
		Manual operation active
	Displayed channel indication is adjustable	Adjustment mode for displayed channel

System Screen

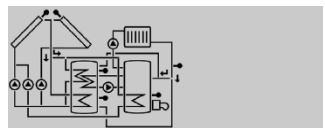

The system screen (active system scheme) shows the scheme selected on the controller. It consists of several component symbols, which are – depending on the current status of the system – either flashing, permanently shown or hidden.

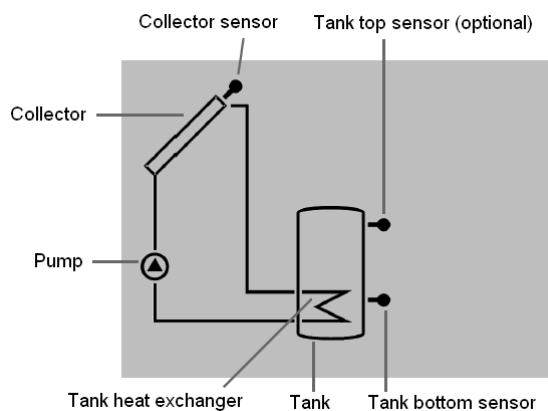

Blinking control symbols

- Pump is blinking while running
- Sensors are blinking if the respective sensor indication channel is selected
- Sensors are quickly blinking if there is a sensor error

Operation control lamp indication

Constantly green:	system operation normal
Red/green blinking:	initialization phase, manual operation
Red blinking:	sensor error

STARTUP / SYSTEM SETTINGS

The AC power cord should be plugged in to an appropriate 115V outlet. The controller will enter an initialization phase in which the operating control lamp will flash red and green. After the initialization period the controller will be in automatic operation with the default settings active.

The pre-adjusted system scheme is ARR 1. Other system settings are available, but this setting should not be changed for the system included in this package.

The controller is now ready for operation. The following system settings should be made as indicated. The operational system channels are listed in order of appearance by pressing the forward (1) button.

COL:

Collector Temperature
Display range: -40 to +482 °F



Shows the current collector temperature.

TST:

Tank temperature
Display range: -40 to +482 °F

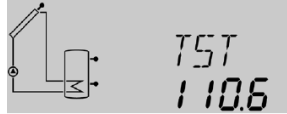

Shows the current tank temperature (from tank bottom sensor).

S3, S4:

Additional sensor temperature
Display range -40 to +482 °F

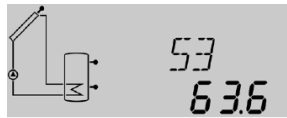

Shows the current temperature of the corresponding optional sensor (without control function).

S3 and S4 are only indicated if the temperature sensors are connected.

TRF:

Temperature return flow
Display range -40 to +482 °F



Shows the current temperature of the optional temperature return flow sensor (S4) when the heat quantity measurement option is activated.

hP:

Operating hours counter
Display channel

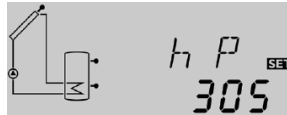

The operating hours counter adds up the solar operating hours of the pump. Full hours are shown on the display.

The total operating hours can be reset. When the operating hours channel is selected the symbol **SET** is permanently shown in the display. The set button (3) must be pressed for approximately 2 seconds in order to go into the reset mode for the counter. The display symbol **SET** will be flashing and the operating hours will be set to 0. In order to finish the reset procedure the set button (3) must be pressed in order to confirm.

In order to interrupt the reset procedure no button should be pressed for about 5 seconds. The controller will automatically return to the indication mode with the previous total.

Once the final display channel is reached the remaining system setting channels may only be accessed by holding the forward (2) button down for approximately 2 seconds. The following setting channels will then be shown:

ARR:

System arrangement setting

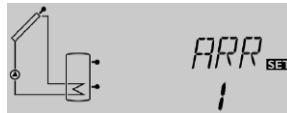

Shows the current system configuration setting. Arrangement 1 should be used for the system in this package and this setting should not be changed.

DTO:

Switch-on temperature diff.
Adjustment range
2.0 to 40.0 °F
Default setting 12.0

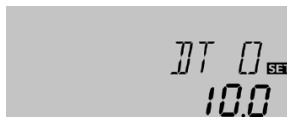

Primarily the controller works in the same way as a standard differential controller. If the switch-on difference, DT O (collector temperature sensor reading minus the tank sensor reading), is reached the pump is activated.

Recommended setting: 10.0

DTF:

Switch-off temperature diff.
 Adjustment range
 1.0 to 38.0 °F
 Default setting 8.0

Recommended setting: 4.0

If the switch-off temperature, DT F, is reached the pump is de-activated.

Note: the switch-off temperature must be at least 2 degrees lower than the switch-on temperature.

SMX:

Maximum tank temperature
 Adjustment range:
 40 to 205 °F
 Default setting 140 °F

Recommended setting: 160 °F

If the maximum tank temperature is reached the control will prevent the pump from operating and heating the tank any further.

Note: The controller will only allow the tank temperature to exceed the maximum tank temperature setting when the optional system cooling function (OCX) is active and the maximum collector temp (CMX) has been exceeded. In this case the pump will run to transfer heat from the collector to the tank to prevent prolonged overheating of the collector. In this case the tank may be heated until it reaches the emergency shutoff point of 203 °F and no further heating will be done.

If the maximum tank temperature setting is exceeded the symbol will be shown on the display.

EM:

Collector temperature limit
 Adjustment range:
 230 to 400 °F
 Default setting: 285 °F

Recommended setting: 285 °F

If the collector temperature limit is reached the solar pump (R1) is deactivated in order to avoid damaging overheating of the solar components (collector emergency shutdown).

If the collector temperature limit setting is exceeded the Δ symbol will be shown flashing on the display.

OCX:

Collector cooling
 Adjustment: OFF / ON
 Default setting: OFF

Recommended setting: ON

This function is used to avoid prolonged periods of excessive collector temperatures. If the maximum tank temperature is reached, the solar system will shut off. After this point if the collector temperature reaches the maximum collector temperature (CMX), the solar pump will activate until the collector temperature drops below the set point. The tank temperature may continue to rise, overriding the maximum tank temperature, but only until it reached the emergency tank shutoff point of 203 °F.

When the system is actively cooling the collectors (CMX exceeded) the \odot symbol will be shown flashing on the display.

CMX:

Maximum collector temp.
 Adjustment range:
 210 to 380 °F
 Default setting: 250 °F
Recommended setting: 250 °F
 Channel only available when
 OCX is active

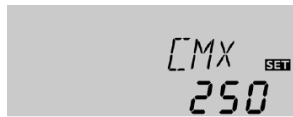

The minimum collector temperature is a minimum switching temperature, which must be exceeded before the solar pump (R1) is switched on. The minimum temperature will avoid short cycling of the solar pump at low collector temperatures. If the collector temperature is lower than the minimum collector temperature set point the \odot symbol will be shown flashing on the display.

This function is unnecessary if the system backup heating element has a set point maintained at 120 °F.

OCN:

Minimum collector limit
 Adjustment: OFF / ON
 Default setting: OFF
Recommended setting: OFF

**CMN:**

Minimum collector temp.
 Adjustment range:
 50 to 195 °F
 Default setting: 50 °F
Recommended setting: 50 °F
 Channel only available when
 OCN is active

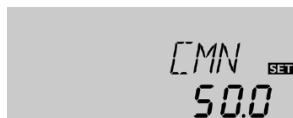

OCF:

Antifreeze function
 Adjustment: OFF / ON
 Default setting: OFF

Recommended setting: OFF



This function is used to transfer heat from the storage tank to the collector in order to avoid freezing of the heat transfer medium in some system types.

This system uses a solution of propylene glycol and water and is freeze resistant to -30 °F; therefore, this function is not necessary.

CFR:

Antifreeze temperature
 Adjustment range:
 15 to 50 °F
 Default setting: 40 °F

Recommended setting: 40 °F

Channel only available when
 OCF is active

Channel only available when OCF is active

**OREC:**

Recooling function
 Adjustment: OFF / ON
 Default setting: OFF

Recommended setting: ON



The recooling function is used to cool the tank when the maximum tank temperature (S MX) is exceeded, such as when the collector cooling function (OCX) is activated and the tank may reach 203 °F (emergency shut down of the tank).

When the collector is 5° cooler than the tank the pump will run to dump excess heat from the tank in the piping and at the solar collector until the tank is cooled to the maximum tank temperature setting.

The tube collector function is only needed for systems that use vacuum tube solar collectors.

This function is not necessary for this system.

OTC:

Tube collector function
 Adjustment: OFF / ON
 Default setting: OFF

Recommended setting: OFF

**OHQM:**

Heat quantity measurement
 Adjustment: OFF / ON
 Default setting: OFF

Recommended setting: OFF



A Heat quantity measurement is possible for this system in conjunction with the flow meter. In order for this function measure the heat gain of the system the optional temperature sensor 4 (return flow sensor) must be added and connected to the copper pipe between the coil outlet on the tank (marked "to pump") and the solar pump station.

FMAX:

Volume flow in gal/min
 Adjustment range:
 0.0 to 20.0 in steps of 0.1
 Default setting: 6.0

Recommended setting: pump station flow meter reading.

Channel only available when OHQM is active



For OHQM to give an accurate reading the volume flow readable at the flowmeter (gal/min) must be adjusted in the channel FMAX.

MEDT:

Type of antifreeze
 Adjustment range: 0 to 3
 Default setting: 1

Recommended setting: 1

Channel only available when
 OHQM is active.



For OHQM to give an accurate reading the type of heat transfer fluid type(antifreeze) must be set in the channel MEDT:

- 0: water
- 1: propylene glycol
- 2: ethylene glycol
- 3: Tyfocor® LS / G – LS

Caution: for this system type only type 1: propylene glycol should be selected. Use of any other type of heat transfer fluid in this system may cause damage to the system or present a health hazard

MED%:

Concentration of antifreeze by volume %

Adjustment range: 20 to 70%

Default setting: 45

Recommended setting: 50

Channel only available when OHQM is active.



The antifreeze concentration by % volume should be entered in this channel for OHQM to give an accurate reading.

Standard system concentration should be a 50% propylene glycol and 50% distilled or de-mineralized water.

kWh/MWh:

Heat quantity value shown in the kWh and MWh display channels. The sum of both channels form the total heat output.

Channel only available when OHQM is active



The total heat quantity value can be reset. When one of the heat quantity display channels is selected the symbol **SET** is permanently shown in the display. The set button (3) must be pressed for approximately 2 seconds in order to go into the reset mode for the counter. The display symbol **SET** will be flashing and the value for heat quantity will be set to 0. In order to finish the reset procedure the set button (3) must be pressed in order to confirm.

In order to interrupt the reset procedure no button should be pressed for about 5 seconds. The controller will automatically return to the indication mode with the previous total.

For system setup and service work the operating mode of the pump can be manually adjusted by selecting the adjustment value for HND 1 (primary pump) or HND 2 (optional secondary pump, not included).

Operating mode:

OFF: relay off Δ (flashing) +

AUTO: relay in automatic operation

ON: relay on Δ (flashing) +

HND 1, HND 2:

Pump operating mode

Adjustment range:

OFF / AUTO / ON

Default setting: AUTO



The menu language can be adjusted in this channel:

De: German

En: English

It: Italian

Fr: French

LANG:

Controller language

Adjustment range:

De, En, It, Fr

Default setting: En



The temperature unit can be adjusted in this channel:

FAH: °Fahrenheit

CEL: °Celsius

UNIT:

Temperature units



Adjustment: FAH, CEL

Default setting: FAH



The final two channels indicate the current program and version number for the controller. To exit out of the system setting mode press the backward button (2) repeatedly until you reach the first display channel (COL).

TROUBLESHOOTING

PROBLEM	CHECK THIS	POSSIBLE CAUSE	CORRECTIVE ACTION
No hot water	Storage water heater	No power to auxiliary back-up heating element	Check high temperature protection and push reset button on the heater thermostat. (Use caution when dealing with electricity.)
	Storage water heater thermostat	Thermostat defective	Replace
	Thermostatic mixing valve	Improper adjustment	Check water temperature at house faucet and adjust valve setting
		Valve defective	Replace. System must not be run without thermostatic mixing valve due to scald risk.
Not enough hot water	Storage water heater	Undersized for hot water demand load	Replace
		Thermostat set too low	Increase set point temperature
		Element failure	Replace element
		Thermostat failure	Replace thermostat
		Element disconnected	Reconnect element and set thermostat to 120°F
	Check valve	Heat loss due to defective check valve in solar pump station	Inspect valve and repair or replace
	Cold water supply dip tube	Missing or defective	Replace dip tube
	Collectors	Absorber coating degradation	Replace collector
		Collector panel area undersized	Increase collector area
		Excessive condensation	Inspect and clean weep holes and vents at bottom.
		Glazing dirty	Clean as required
		Leaks	Repair
		Orientation	Check orientation. Face collector within 45° of due South
		Shaded by tree(s) or other obstructions	Remove obstacle and shading or relocate collectors
		Improper tilt	Check tilt for geographic area. Ensure tilt is equal to latitude plus 15°
		Improperly plumbed	Compare with system schematic and correct.
	Differential Controller	Improper operation (cycling, late turn on)	Check sensor placement and insulation from ambient conditions
		Faulty sensor  is shown and control reads 888.8 instead of temperature	Sensor line break. Check the line and repair or replace
		Faulty sensor  is shown and control reads -88.8 instead of temperature	Short circuit. Check the line for breaks, metal contact, water exposure and corrosion.

PROBLEM	CHECK THIS	POSSIBLE CAUSE	CORRECTIVE ACTION
Not enough hot water (cont.)	Differential Controller	Improper wiring or loose connections)	Compare with system schematic. Check for proper connections. Seal all splices against moisture
	Isolation valves	Closed	Open
	Thermostatic mixing valve	Improper adjustment	Check water temperature at house faucet and adjust valve setting
		Valve defective	Replace. System must not be run without thermostatic mixing valve due to scald risk.
	Piping	Insufficient Insulation	Add insulation where required
		High heat losses	Check insulation for splits, deterioration, absence
		Nighttime thermosyphoning	Check for pump operation at night
		Improperly plumbed	Compare with system schematic. Check flow direction
		Flow blockage	Flush system. Check effluent for debris.
		Low system pressure	Check pressure gauge. Set system pressure to correct setting, check for leaks.
	Pump	No power	Check breaker, pump cord, and controller fuse. Repair or replace
		Flow rated too high or too low	Adjust flow rate
		Faulty pump	Listen for irregular noises in pump operation. Feel collector feed and return line for temperature difference. Ensure all air is purged from system.
	Runs continuously	Check sensors for shorts	
No hot water in the morning	Storage water heater	Circuit breaker shut off	Turn breaker on
	Differential controller	Sensor wires reversed	Ensure the collector and tanks sensors are wired to the correct position on the controller
Water too hot	Thermostatic mixing valve	Improper adjustment	Check water temperature at house faucet and adjust valve setting
		Valve defective	Replace. System must not be run without thermostatic mixing valve due to scald risk.
No water	Cold-water supply valve	Valve closed	Open valve
Pump does not start	Differential controller	Controller set to "off" position	Set system operation to "Auto"
		Unplugged	Return power to controller
		On and/or off temperature differential set points too high	Reset on and off differentials according to recommendations
		Loose contacts	Clean contacts and tighten connections or replace
		Blown fuse	Replace fuse

PROBLEM	CHECK THIS	POSSIBLE CAUSE	CORRECTIVE ACTION	
Pump does not start	Electrical power supply	Controller plug disconnected	Reconnect control plug to power outlet	
		Blown fuse or breaker tripped on overload	Determine cause and replace fuse or reset breaker	
	Pump	Motor failure	Replace pump	
	Sensors	Defective sensors, sensor error	Check wiring continuity. Repair or replace	
Pump starts, but cycles continuously	Differential controller	On and/or off temperature differential set points too low	Reset on and off differentials according to recommendations	
	Piping	Reversed connections to collectors	Compare with system schematic and reconnect properly	
	Sensors	Improper location	Compare with system schematic and reconnect properly	
Pump cycles after dark	Differential controller	Recooling function active and max temperature setting exceeded	Controller operating properly. No fault.	
	Sensors	Defective sensors, sensor error	Check wiring continuity. Repair or replace	
Pump runs continuously	Differential controller	Off temperature differential set too low	Reset off differential according to recommendation	
		Controller set to "on" position	Set system operation to "Auto"	
Pump operated but no fluid flows from collectors	Airstop	System air-locked	Purge air from airstop in solar pump station by opening valve slowly. Caution: after air is evacuated fluid will flow out in a small stream and may be hot. Cover port with a rag to catch any fluid.	
	Air vent	System air-locked	Open air vent on the top of the system and purge excess air. Close after purging.	
	Fluid	Loss of fluid from system	Locate leak and repair	
	Isolation valves	Valves in closed position	Open valves	
	Piping	Clogged or damaged piping	Unblock piping or repair damaged piping	
	Pump	Broken impeller shaft	Not vented properly	Install in correct orientation
			Undersized	System piping run too long. Refer to maximum piping lengths and adjust
Noisy system	Air vents	Air trapped in system	Open automatic air vent and purge airstop in solar pump station by opening the valve slowly. Caution: after air is evacuated fluid will flow out in a small stream and may be hot. Cover port with a rag to catch any fluid.	
	Pump	Bearings are dry or have excessive wear	Lubricate or replace	
		Impeller loose	Tighten or replace impeller	

SYSTEM MAINTENANCE

HEAT TRANSFER FLUID (HTF) QUALITY

The chemical composition of the HTF may change over time. The HTF quality should be monitored on a periodic basis – at least annually. After summer and before any chance of the first freeze is an ideal time. A drop in pH can indicate the system has been stagnating frequently. The cause should be determined and corrected.

To test the pH level, use a digital pH tester or tight range litmus paper. Remove a small sample of the fluid from the airtop on the pump station. The pH should be between 8.1 and 12.0. Fluid with pH between 7.5 and 8.1 can be conditioned by your contractor using an inhibitor boost. Fluid with pH above 12.0 or that is dark, dirty or has an acidic smell should be replaced.

PIPING AND EXTERNAL INSULATION

On an annual basis, all piping should be checked for leakage at joints, and unions. Any damaged external insulation should be repaired or replaced.

WIRING AND CONNECTIONS

On an annual basis, check wiring and connections, including sensor wiring and splices. Look for signs of overheating, discoloration, corrosion or loose connections. Any damaged wiring should be repaired or replaced.

FLUID LEAKS

If you detect a glycol or water leak, or the glycol loop pressure drops unexpectedly, contact your installation contractor immediately to diagnose the problem and recharge the system.

SOLAR PANEL CLARITY

If you live in a dusty climate, once a month wash off dirt that settles on the solar panel glass. Clean glass allows the solar panel to maintain a high level of thermal performance.

EXPANSION TANK

Annually check condition of the solar expansion tank. Check to see if it is waterlogged by quickly pressing schrader valve stem at bottom of the tank. You should get a quick burst of air. If fluid is discharged, the tank may be waterlogged and need replacement. Contact a qualified solar installer if the tank needs replacement.

VACATION

For extended periods with no hotwater usage such as vacation it is recommend that the max. tank temperature (S MX) in the solar control be set to 120°F. This maximizes the storage capacity of heat build-up during the day using the CMX function for maximum collector temperature and will aid in preventing breakdown of the heat transfer fluid due to overheating.

REPAIR PARTS

REPAIR PARTS SCHEDULE

ORDERING REPAIR PARTS

The following parts may be ordered through the store or dealer from whom you purchased the solar water heater, or direct from the factory listed on the model & rating plate located on the lower front of the solar water heater and by phone at 1-800-433-2545. Selling prices will be furnished on request or parts will be shipped at prevailing prices and you will be billed accordingly. When ordering repair parts always give the following information: (1) Part description, (2) Model serial number, (3) Element wattage, (4) Voltage, (5) Part number.

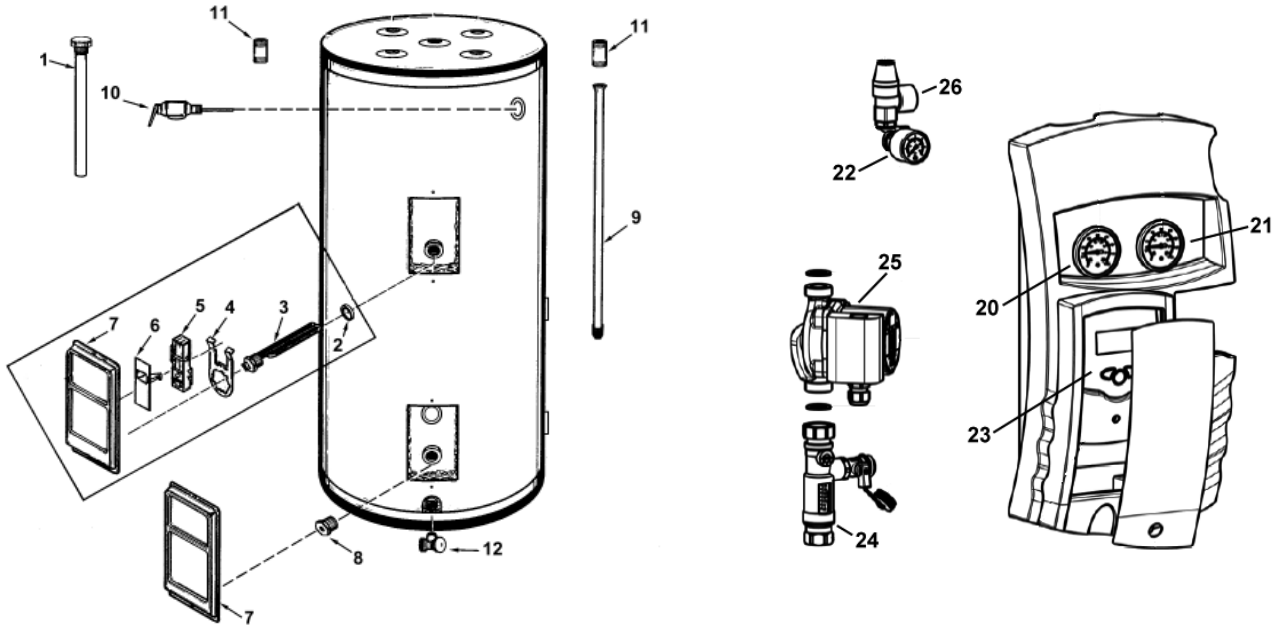

ITEM	PART DESCRIPTION	SERVICE PART #
1	Primary Anode	9006914005
2	Element Gasket	9000308005
3	Element	9000095005
4	Thermostat Bracket	9000309015
5	Thermostat w/Hi Limit	9000509015
6	Terminal Cover	9002438015
7	Access Panel	9003900005
8	Sensor Mounting Plug	9007309005
9	Dip Tube with Diffuser	9002549005
10	T&P Valve	9000728015
11	Heat Trap Nipple	9003915015
12	Drain Valve	9003906015
13	Solar Collector CR110 (Not Pictured)	9007447005
14	Water Tempering (Mixing) Valve (Not Pictured)	9007448005
15	Temperature Sensor Control Wire Assy 75' Roll (Not Pictured)	9007449005
16	Propylene Glycol (DOWFROST HD) 5-gallon (Not Pictured)	9007450005
17	Air Vent (Not Pictured)	9007451005
18	Solar Loop Expansion Tank (Not Pictured)	9007456005
19	Roof Flashing (Multi Port) (Not Pictured)	9007457005
20	Temperature Gauge-Supply (Red)	9007452005
21	Temperature Gauge-Return (Blue)	9007453005
22	Pressure Gauge	9007454005
23	Solar Control	9007458005
24	Flowmeter	9007459005
25	Pump w/Seal Kit	9007455005
26	Pressure Relief Valve	9007460005
27	Collector Temperature Sensor (Not Pictured)	9007461015
28	Tank Temperature Sensor (Not Pictured)	9007462015

